

Test summary

Shipped 4/20/99

Laser head S/N 1798

T40 S/N 81703

Remot S/N 21594

Diode 1 S/N 0P266YN022

Diode 2 S/N 0P266SN02

Z Head S/N 815

Oven S/N 2110

Software Rev.

T40: -4420 J

Head: 4.11

Remot: 4.12

Diode #1 currs @ 13W

24.15 A. 29.00° C

#2

23.35 A. 28.00° C

Power @ 532nm. @ 26W pump  $\geq 5.5W$ ,

noise @ 532nm  $\leq 0.1\%$  rms

Z head power (no aperture) 14.50 W.

Mechanical stability

current mode  $\leq 1\%$

power mode  $\leq 1\%$

Current req'd for 5W @ 532nm.

Diode 1

23.0 A

Diode 2

21.8 A.

# Millennia™ V

## Diode-pumped, cw Visible Laser

average lifetime of diodes: 5000 hrs.

### User's Manual



1335 Terra Bella Avenue  
Post Office Box 7013  
Mountain View, CA 94039-7013

Part Number 0000-245A, Rev. C  
August 1998



## Preface

---

This manual contains information you need in order to safely install, align, operate, maintain, and service your Millennia diode-pumped, continuous-wave, visible laser. The system comprises four elements: the Millennia laser head, the T40 power supply, the chiller and the control module. The latter is a table-top controller that is provided with the system.

The “Introduction” contains a brief description of the Millennia laser and its power supply, controller and chiller.

Following that section is an important chapter on safety. The Millennia is a Class IV laser and, as such, emits laser radiation which can permanently damage eyes and skin. This section contains information about these hazards and offers suggestions on how to safeguard against them. To minimize the risk of injury or expensive repairs, be sure to read this chapter—then carefully follow these instructions.

“Laser Description” contains a short section on laser theory regarding the Nd:YVO<sub>4</sub> crystal and second harmonic generation used in the Millennia. It is followed by a more detailed description of the Millennia laser system. The chapter concludes with system specifications.

The next few chapters describe the Millennia controls, then guide you through its installation, alignment and operation. The last part of the manual covers maintenance and service and includes a replacement parts list and a list of world-wide Spectra-Physics service centers you can call if you need help.

Whereas the “Maintenance” section contains information you need to keep your laser clean and operational on a day-to-day basis, “Service and Repair” is intended to help you guide your Spectra-Physics field service engineer to the source of any problems. *Do not attempt repairs yourself while the unit is still under warranty*; instead, report all problems to Spectra-Physics for warranty repair.

This product has been tested and found to conform to “Directive 89/336/EEC for electromagnetic Compatibility.” Class A compliance was demonstrated for “EN 50081-2:1993 Emissions” and “EN 50082-1:1992 Immunity” as listed in the official *Journal of the European Communities*. It also meets the intent of “Directive 73/23/EEC for Low Voltage.” Class A compliance was demonstrated for “EN 61010-1:1993 Safety Requirements for Electrical Equipment for Measurement, Control and Laboratory use” and “EN 60825-1:1992 Radiation Safety for Laser Products.” Refer to the “EC Declaration of Conformity” statements in Chapter 2.

Finally, if you encounter any difficulty with the content or style of this manual, please let us know. The last page is a form to aid in bringing such problems to our attention.

Thank you for your purchase of Spectra-Physics instruments.

# Table of Contents

---

|  |             |
|--|-------------|
| <b>Preface</b> .....   | <b>iii</b>  |
| <b>Table of Contents</b> .....   | <b>v</b>    |
| <b>Warnings</b> .....  | <b>ix</b>   |
| <b>Standard Units</b> .....  | <b>xi</b>   |
| <b>Unpacking and Inspection</b> .....  | <b>xiii</b> |
| System Components .....  | xiii        |
| Accessory Kit .....  | xiii        |
| <b>Chapter 1: Introduction</b> .....   | <b>1-1</b>  |
| The Millennia™ V Advantage .....   | 1-1         |
| The Laser System .....   | 1-2         |
| Laser Head .....   | 1-2         |
| Power Supply .....   | 1-2         |
| Chiller .....  | 1-3         |
| Control Module .....   | 1-3         |
| Patents .....  | 1-3         |
| <b>Chapter 2: Laser Safety</b> .....   | <b>2-1</b>  |
| Precautions For The Safe Operation<br>Of Class IV High Power Lasers .....  | 2-1         |
| Maintenance Necessary to Keep this Laser Product in Compliance with<br>Center for Devices and Radiological Health (CDRH) Regulations ..... | 2-3         |
| CDRH Requirements for operation with the Control Module .....  | 2-3         |
| Cover Safety Interlock .....   | 2-4         |
| Laser Head .....   | 2-4         |
| Power Supply .....   | 2-4         |
| CDRH/CE Radiation Control Drawing .....  | 2-6         |
| CDRH/CE Warning Labels .....   | 2-7         |
| EC Declaration of Conformity (Emissions) .....   | 2-8         |
| EC Declaration of Conformity (Low Voltage) .....   | 2-9         |
| Sources for Additional Information .....   | 2-10        |
| <b>Chapter 3: Laser Description</b> .....  | <b>3-1</b>  |
| A Brief Review of Laser Theory .....   | 3-1         |
| Emission and Absorption of Light* .....  | 3-1         |
| Population Inversion .....   | 3-2         |
| Resonant Optical Cavity .....  | 3-4         |
| Nd <sup>3+</sup> as a Laser Medium .....   | 3-5         |

|                                  |      |
|----------------------------------|------|
| Diode-pumped Laser Design .....  | 3-6  |
| Frequency Doubling .....         | 3-8  |
| The Millennia V System .....     | 3-10 |
| Overview .....                   | 3-10 |
| The Millennia V Laser Head ..... | 3-12 |
| The Z-head .....                 | 3-12 |
| The Frequency Doubling Arm ..... | 3-13 |
| The Beam Delivery Arm .....      | 3-14 |
| The T40 Power Supply .....       | 3-14 |
| FCbar .....                      | 3-14 |
| The FCbar System .....           | 3-14 |
| Specifications .....             | 3-15 |
| Outline Drawings .....           | 3-17 |

**Chapter 4: Controls, Indicators and Connections .....** **4-1**

|                                  |     |
|----------------------------------|-----|
| Introduction .....               | 4-1 |
| Laser Head Controls .....        | 4-1 |
| External Controls .....          | 4-1 |
| Internal Controls .....          | 4-2 |
| Indicators .....                 | 4-2 |
| Connections .....                | 4-3 |
| Millennia V Control Module ..... | 4-4 |
| Controls .....                   | 4-4 |
| Indicators .....                 | 4-4 |
| Connections .....                | 4-5 |
| T40 Power Supply .....           | 4-5 |
| Controls .....                   | 4-6 |
| Indicators .....                 | 4-6 |
| Connections .....                | 4-7 |

**Chapter 5: Installation and Alignment .....** **5-1**

|                                     |     |
|-------------------------------------|-----|
| Laser Installation .....            | 5-1 |
| Installing the Laser Head .....     | 5-1 |
| Installing the Control Module ..... | 5-2 |
| Installing the Power Supply .....   | 5-3 |
| Installing the Chiller .....        | 5-3 |
| Alignment .....                     | 5-4 |

**Chapter 6: Operation .....** **6-1**

|   |      |
|---|------|
| Using the Control Module .....            | 6-1  |
| The Menu System .....                     | 6-2  |
| The Main Menu .....                       | 6-3  |
| The Setup Menu .....                      | 6-4  |
| The Standby Menu .....                    | 6-5  |
| The Information Menu .....                | 6-5  |
| System Start-up/Shut Down .....           | 6-6  |
| Turning On the Laser, Cold Start .....    | 6-6  |
| Turning On the Laser, Warm Start .....    | 6-8  |
| Optimizing Laser Output .....             | 6-9  |
| Turning Off the Laser .....               | 6-10 |
| Setting the SHG Crystal Temperature ..... | 6-11 |
| The RS-232 Serial Port .....              | 6-12 |

|  |            |
|--|------------|
| Pinout/Wiring .....                                      | 6-12       |
| Communications Parameters .....                          | 6-12       |
| Command/Query/Response Format .....                      | 6-13       |
| Commands .....   | 6-13       |
| Queries .....  | 6-14       |
| <b>Chapter 7: Maintenance .....</b>                      | <b>7-1</b> |
| Preventive Maintenance .....                             | 7-1        |
| Equipment Required .....                                 | 7-1        |
| Cleaning Laser Optics and Optical Fibers .....           | 7-1        |
| General Procedure for Cleaning Optics .....              | 7-4        |
| General Procedure for Cleaning Fiber-optic Bundles ..... | 7-5        |
| <b>Chapter 8: Service and Repair .....</b>               | <b>8-1</b> |
| Troubleshooting Guide .....                              | 8-1        |
| Replacement Parts .....                                  | 8-4        |
| <b>Chapter 9: Customer Service .....</b>                 | <b>9-1</b> |
| Customer Service .....                                   | 9-1        |
| Warranty .....   | 9-1        |
| Return of the Instrument for Repair .....                | 9-2        |
| Service Centers .....                                    | 9-3        |
| <b>Appendix A: Status Codes .....</b>                    | <b>A-1</b> |

**Notes**

**Spectra-Physics Lasers User's Manual—  
Problems and Solutions**

**List of Figures**

Figure 1-1: The Millennia V System ..... 1-1

Figure 2-1: These CE and CDRH standard safety warning labels would be appropriate for use as entry warning signs (EN 60825-1, ANSI 4.3.10.1). ..... 2-2

Figure 2-2: Folded Metal Beam Target ..... 2-2

Figure 2-3: The Power Supply Connector Panel. .... 2-3

Figure 2-4: Laser Head Emission Indicator, Shutter and Safety Interlock. .... 2-5

Figure 3-1: Electrons occupy distinct orbitals that are defined by the probability of finding an electron at a given position, the shape of the orbital being determined by the radial and angular dependence of the probability. .... 3-2

Figure 3-2: A Typical Four-level Transition Scheme ..... 3-3

Figure 3-3: Frequency Distribution of Longitudinal Modes for a Single Line ..... 3-4

Figure 3-4: Energy Level Scheme for the Nd<sup>3+</sup> Ion. .... 3-5

Figure 3-5: Nd<sup>3+</sup> absorption spectra compared to emission spectra of a Black Body Source (a), Krypton Arc Lamp (b) and a Laser Pump Diode (c). .... 3-6

Figure 3-6: Mode Matching ..... 3-7

Figure 3-7: The quiet multi-axial mode-doubling (QMAD) solution to the “green problem.” (a) The “green problem.” Intracavity frequency doubling in a laser with a few axial modes produces large amplitude fluctuations in the second harmonic output resulting from nonlinear coupling of the modes through sum-frequency mixing. (b) The single-frequency solution forces oscillation on a single axial mode to eliminate mode coupling. (c) The QMAD solution produces oscillation on many axial modes, effectively averaging the nonlinear coupling terms to provide highly stable second-harmonic output. .... 3-9

Figure 3-8: The Millennia V System (chiller not shown) ..... 3-10

Figure 3-9: Schematic of the Millennia V Laser Head ..... 3-11

Figure 3-10: Schematic of the Millennia Laser Head ..... 3-11

Figure 3-11: The Z-Head (top view) ..... 3-13

Figure 4-1: The Millennia V Laser Head ..... 4-1

Figure 4-2: The Millennia V Laser Head Rear Panel ..... 4-3

Figure 4-3: The Millennia V Control Module ..... 4-4

Figure 4-4: The T40 Power Supply Control Panel ..... 4-5

Figure 5-1: The Millennia V Laser Head Rear Panel ..... 5-2

Figure 6-1: The Millennia V Controller Showing the Default Main Menu. .... 6-1

Figure 6-2: The Millennia V Menus ..... 6-2

Figure 6-3: Millennia V Rear Panel ..... 6-9

Figure 6-4: Laser head pc board showing location of baud rate dip switch S<sub>1</sub>. .... 6-12

Figure 7-1: Lens Tissue Folded for Cleaning ..... 7-4

**List of Tables**

Table 3-1: Millennia V Specifications ..... 3-15

Table 6-1: Query Errors. .... 6-16







Table 6-2: Error Return List. .... 6-16



## Warning Conventions

The following warnings are used throughout this manual to draw your attention to situations or procedures that require extra attention. They warn of hazards to your health, damage to equipment, sensitive procedures, and exceptional circumstances. All messages are set apart by a thin line above and below the text as shown here.

---

|   |  |
|---|--|
|  <b>Danger!</b><br>Laser Radiation | Laser radiation is present.  |
| <b>Danger!</b>                    | Conditions or action may present a hazard to personal safety.          |
| <b>Warning!</b>                  | Condition or action may cause damage to equipment.                     |
| <b>Caution!</b>                  | Condition or action may cause poor performance or error.               |
| <b>Note</b>                      | Text describes exceptional circumstances or makes a special reference. |
| <b>Don't Touch!</b>              | Do not touch.  |
| <b>Eyewear Required</b>          | Appropriate laser safety eyewear should be worn during this operation. |

---



## Standard Units

---

The following units, abbreviations, and prefixes are used in this Spectra-Physics manual:

| Quantity              | Unit     | Abbreviation |
|-----------------------|----------|--------------|
| mass                  | kilogram | kg           |
| length                | meter    | m            |
| time                  | second   | s            |
| frequency             | hertz    | Hz           |
| force                 | newton   | N            |
| energy                | joule    | J            |
| power                 | watt     | W            |
| electric current      | ampere   | A            |
| electric charge       | coulomb  | C            |
| electric potential    | volt     | V            |
| resistance            | ohm      | $\Omega$     |
| inductance            | henry    | H            |
| magnetic flux         | weber    | Wb           |
| magnetic flux density | tesla    | T            |
| luminous intensity    | candela  | cd           |
| temperature           | celcius  | C            |
| pressure              | pascal   | Pa           |
| capacitance           | farad    | F            |
| angle                 | radian   | rad          |

### Prefixes

|      |               |   |       |               |       |       |                |   |
|------|---------------|---|-------|---------------|-------|-------|----------------|---|
| tera | ( $10^{12}$ ) | T | deci  | ( $10^{-1}$ ) | d     | nano  | ( $10^{-9}$ )  | n |
| giga | ( $10^9$ )    | G | centi | ( $10^{-2}$ ) | c     | pico  | ( $10^{-12}$ ) | p |
| mega | ( $10^6$ )    | M | mill  | ( $10^{-3}$ ) | m     | femto | ( $10^{-15}$ ) | f |
| kilo | ( $10^3$ )    | k | micro | ( $10^{-6}$ ) | $\mu$ | atto  | ( $10^{-18}$ ) | a |



# Unpacking and Inspection

---

## Unpacking Your Laser

Your Millennia V laser was packed with great care, and its container was inspected prior to shipment—it left Spectra-Physics in good condition. Upon receiving your system, immediately inspect the outside of the shipping containers. If there is any major damage (holes in the containers, crushing, etc.), insist that a representative of the carrier be present when you unpack the contents.

Carefully inspect your laser system as you unpack it. If any damage is evident, such as dents or scratches on the covers or broken knobs, etc., immediately notify the carrier and your Spectra-Physics sales representative.

**Keep the shipping containers.** If you file a damage claim, you may need them to demonstrate that the damage occurred as a result of shipping. If you need to return the system for service at a later date, the specially designed container assures adequate protection.

## System Components

The following components comprise the Millennia V laser system:

- Millennia V Laser Head
- T40 Power Supply
- Chiller
- Control Module

Verify all four components are present. The laser head, power supply, and controller are shipped in one container; the chiller is shipped separately.

## Accessory Kit

Included with the laser system is this manual, a packing slip listing all the parts shipped, and an accessory kit containing the following items:

- 1 US or European (German) power cord, 2 m
- 2 large-handled  $\frac{3}{32}$  in. Allen ball drivers for adjusting the vertical and horizontal controls of the high reflector.
- a  $\frac{5}{32}$  in. Allen (hex) driver for adjusting the feet (laser height)
- table clamp kit: 4 clamps and hardware
- plastic hemostat

- lens tissue
- tweezers
- 2 keys for the power supply
- Z-head output coupler
- fiber endcaps
- Z-head telescope endcaps
- jumper plug for RS-232 only operation.

## The Millennium™ V Advantage

The Millennium V is an *all solid-state*, high power, visible cw laser that provides greater than 5 W of green 532 nm output from a standard 110 or 220 Vac, single-phase outlet. The laser head has the same footprint and output beam position as conventional small-frame ion lasers, and offers beam quality, beam pointing, and amplitude stability that are equal to or better than ion lasers. In addition, the optical noise is more than an order of magnitude lower than that of an ion laser.

All this performance is possible through the integration of our patented, high-efficiency *FCbar™* diode-pumping and QMAD intracavity-doubling technologies.

Because the Millennium V is all solid-state, it is much more reliable and easier to use than an ion laser. With its much greater conversion efficiency (<500 W of waste heat vs. about 20 kW for a small-frame ion laser), its operating cost is much lower.

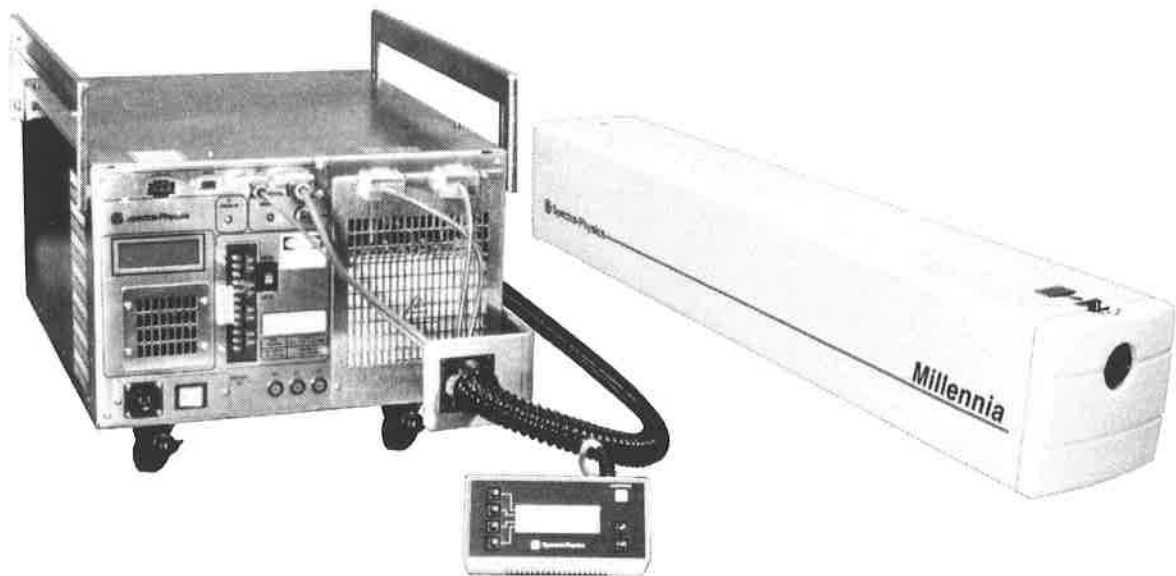

Figure 1-1: The Millennium V System

## The Laser System

The Millennia V system comprises four basic components:

- Millennia V laser head
- T40 power supply
- Chiller
- Control Module

### Laser Head

The Millennia V laser head houses the optical resonator, the neodymium yttrium vanadate (NdYVO<sub>4</sub>) gain medium, the diode laser fiber delivery and telescope focusing systems, the lithium triborate (LBO) doubling crystal, and the output beam telescope system. Externally, it resembles a standard, small-frame ion laser head. Indeed, its dimensions, overall footprint and output beam location make it a drop-in replacement for one. However, because there is no plasma tube, magnet, or water jacket, the Millennia V laser head is shorter and weighs far less than an equivalent ion laser head; it can even be handled and moved easily by one person.

In addition, because the laser head is not subjected to the large heat load of a plasma tube nor required to support a heavy magnet assembly, only a simple resonator design is employed. Nevertheless, it is sufficiently robust to deliver beam pointing stability as good as that from an actively stabilized ion laser. To further improve stability and provide long-term, hands-off operation, the entire intracavity beam path is totally enclosed.

The highly efficient, diode-pumped Nd:YVO<sub>4</sub> laser crystal requires far less cooling water flow than a plasma tube of comparable output power—*over two orders of magnitude less!* This virtually eliminates low-frequency optical noise, which is a major problem for water-cooled ion lasers. A small chiller is provided to supply this cooling.

The noncritically phase-matched LBO doubling crystal is housed in an oven that maintains it at an optimum temperature for stable output.

### Power Supply

The T40 power supply houses the two fiber-coupled, 20 W diode laser bars that pump the Millennia V head. Each diode bar is operated at less than 75% of its rated power in order to maintain ideal operating conditions for the diodes and, thus, ensure a long lifetime. The power supply also contains the control logic and power modules for the system, as well as the refrigeration unit that cools the diodes.

The power supply is air cooled and requires no water or external cooling connections. For electrical power, it simply requires a standard 110 or 220 Vac 10 A power source.

The power supply is small, about 31 x 41 x 64 cm (13 x 16 x 25 in.), and it weighs about 50 kg (110 lb). Rubber casters are provided for mobility and to permit easy stowage. It can also be rack-mounted.



A single umbilical cable connects the supply to the laser head. It contains the power and control cables, fiber bundles, and cooling lines.

### **Chiller**

The compact recirculating chiller regulates the temperature of the Nd:YVO<sub>4</sub> crystal in the laser head, and the cooling fluid temperature is displayed on the chiller for easy monitoring. Because the Millennia V is a closed-loop system, it requires no facility water connections.

### **Control Module**

The Millennia V controller provides easy control from virtually any point in the laboratory. An 8-foot cable connects the controller to the laser head.

A simple, menu-driven control program that uses “soft” keys and clear, large characters on a back-lit display provides an easy method of controlling and monitoring the system. The intuitive, layered menu structure provides operational options along with diagnostic information for fast, efficient control of the unit.

For users that prefer to operate the laser remotely, either directly or via a computer program, a standard serial link is provided on the laser head for connection to a computer or terminal.

### **Patents**

The Millennia V system is manufactured under the following patents:

|           |           |           |
|-----------|-----------|-----------|
| 4,653,056 | 4,761,785 | 4,942,582 |
| 4,656,635 | 4,785,459 | 5,080,706 |
| 4,665,529 | 4,837,771 | 5,127,068 |
| 4,701,929 | 4,872,177 | 5,410,559 |
| 4,723,257 | 4,894,839 | 5,412,683 |
| 4,739,507 | 4,908,832 | 5,436,990 |
| 4,756,003 | 4,913,533 | 5,446,749 |





The Spectra-Physics Millennia V laser is a *Class IV—High Power Laser* whose beam is, by definition, a safety and fire hazard. Take precautions to prevent accidental exposure to both direct and reflected beams. Diffuse as well as specular beam reflections can cause severe eye or skin damage.

### Precautions For The Safe Operation Of Class IV High Power Lasers

**Eyewear  
Required**



- Wear protective eyewear at all times; selection depends on the wavelength and intensity of the radiation, the conditions of use, and the visual function required. Protective eyewear is available from suppliers listed in the *Laser Focus World*, *Lasers and Optronics*, and *Photonics Spectra* buyer's guides. Consult the ANSI and ACGIH standards listed at the end of this section for guidance.
- Maintain a high ambient light level in the laser operation area so the eye's pupil remains constricted, reducing the possibility of damage.
- To avoid unnecessary radiation exposure, keep the protective cover on the laser head at all times.
- Avoid looking at the output beam; even diffuse reflections are hazardous.
- Avoid blocking the output beam or its reflections with any part of the body.
- Establish a controlled access area for laser operation. Limit access to those trained in the principles of laser safety.
- Post prominent warning signs near the laser operating area (Figure 2-1).
- Set up experiments so the laser beam is either above or below eye level.
- Provide enclosures for beam paths whenever possible.
- Set up shields to prevent any unnecessary specular reflections.
- Set up a beam dump to capture the laser beam and prevent accidental exposure (Figure 2-2).

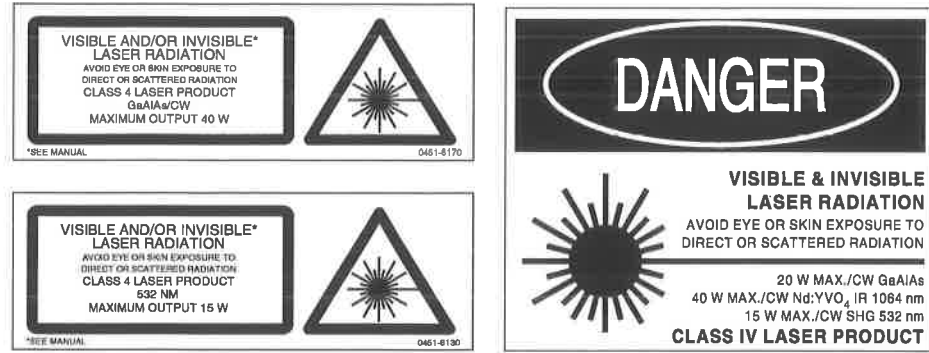

Figure 2-1: These CE and CDRH standard safety warning labels would be appropriate for use as entry warning signs (EN 60825-1, ANSI 4.3.10.1).

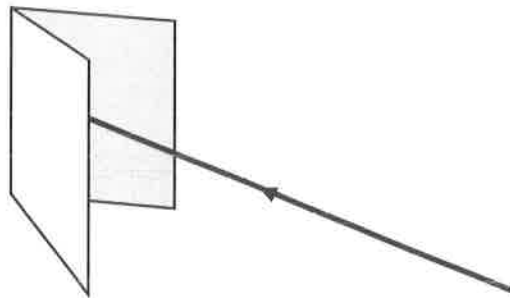

Figure 2-2: Folded Metal Beam Target

Caution!



Use of controls or adjustments, or performance of procedures other than those specified herein may result in hazardous radiation exposure.

Operating this laser without due regard for these precautions or in a manner that does not comply with recommended procedures may be dangerous. At all times during installation, maintenance or service of your laser, avoid unnecessary exposure to laser or collateral radiation\* that exceeds the accessible emission limits listed in "Performance Standards for Laser Products," *United States Code of Federal Regulations*, 21CFR1040.10(d).

Follow the instructions contained in this manual to ensure proper installation and safe operation of your laser.

\* Any electronic product radiation, except laser radiation, emitted by a laser product as a result of or necessary for the operation of a laser incorporated into that product.

## Maintenance Necessary to Keep this Laser Product in Compliance with Center for Devices and Radiological Health (CDRH) Regulations

This laser product complies with Title 21 of the *United States Code of Federal Regulations*, Chapter 1, subchapter J, parts 1040.10 and 1040.11, as applicable. To maintain compliance with these regulations, once a year, or whenever the product has been subjected to adverse environmental conditions (e.g., fire, flood, mechanical shock, spilled solvent, etc.), check to see that all features of the product identified on the CDRH Radiation Control Drawing (found later in this chapter) function properly. Also, make sure that all warning labels remain firmly attached.

1. Verify removing the auxiliary interlock (INTLK AUX) connector on the power supply prevents laser operation.

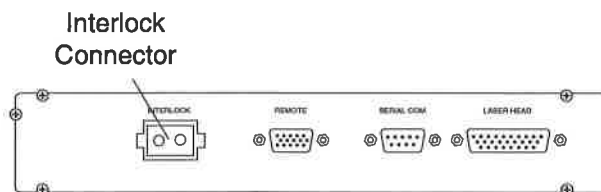

**Figure 2-3: The Power Supply Connector Panel**

2. Verify the laser can only be turned on when the key switch is in the ON position, and that the key can only be removed when the switch is in the off position.
3. Verify the emission indicator provides a visible signal when the laser emits accessible laser radiation that exceeds the accessible emission limits for Class I.\*
4. Verify the time delay between turn-on of the emission indicator and starting of the laser; it must give enough warning to allow action to avoid exposure to laser radiation.
5. Verify the beam attenuator (shutter) actually blocks access to laser radiation.
6. Verify the safety interlock stops emission of laser or collateral radiation upon removal or displacement of the interlocked laser head cover.
7. When the safety interlock is defeated, verify the defeat key is clearly visible and that it prevents replacement of the cover.

\*  $0.39 \mu\text{W}$  for continuous-wave operation where output is limited to the 400 to 1400 nm range.

## CDRH Requirements for operation with the Control Module

The Millennia V laser head and the T40 power supply comply with all CDRH safety standards when operated with the Millennia V control module. However, when the laser is operated through the serial interface (i.e., without the control module), you must provide the following in order to satisfy CDRH regulations:

- **A key switch**—that limits access to the laser and prevents it from being turned on. It can be a real key lock, a removable computer disk, a password that limits access to computer control software, or a similar “key” implementation. The laser must only operate when the “key” is present and in the “on” position.
- **An emission indicator**—that indicates laser energy is present or can be accessed. It can be a “power-on” lamp, a computer display that flashes a statement to this effect, or an indicator on the control equipment for this purpose. It need not be marked as an emission indicator so long as its function is obvious. Its presence is required on any control panel that affects laser output.

## Cover Safety Interlock

The Millennia V system has a safety interlock for the laser head cover only. Removing this cover turns off the laser diodes. The cover must be on, or the interlock defeated, before the laser will operate.

### Laser Head

Installing the safety interlock key in the laser head allows the laser to operate with its cover removed (refer to Figure 2-4).



---

Collateral radiation! While the laser head cover is removed, be extremely careful to avoid exposure to laser or collateral radiation.

---

The laser head cover cannot be replaced until the safety interlock key has been removed. Shut off the laser before removing the interlock key and replacing the cover.

### Power Supply

Because there are no user-serviceable parts inside the power supply or internal adjustments that can be made by the user, the Millennia V T40 power supply requires no cover safety interlock switch.

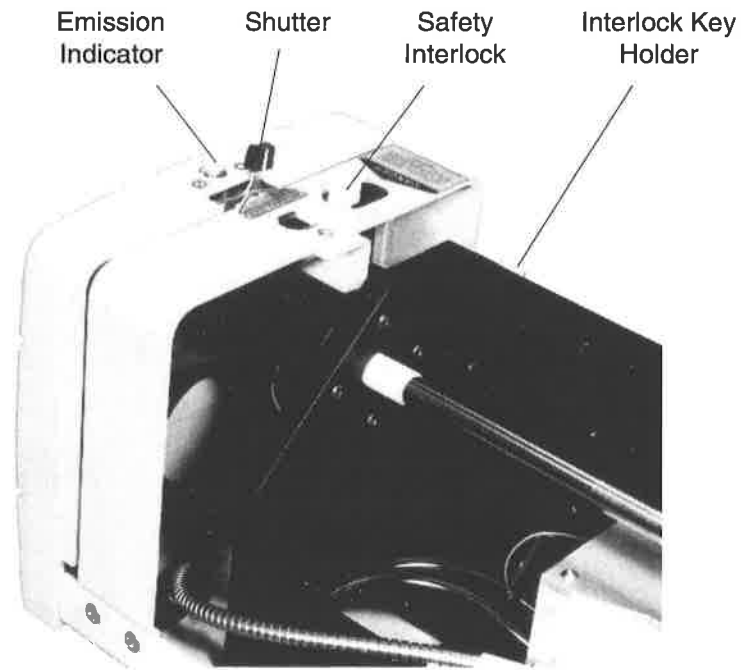

**Figure 2-4: Laser Head Emission Indicator, Shutter and Safety Interlock**

# CDRH/CE Radiation Control Drawing

Refer to the CDRH/CE Warning Labels on the next page.

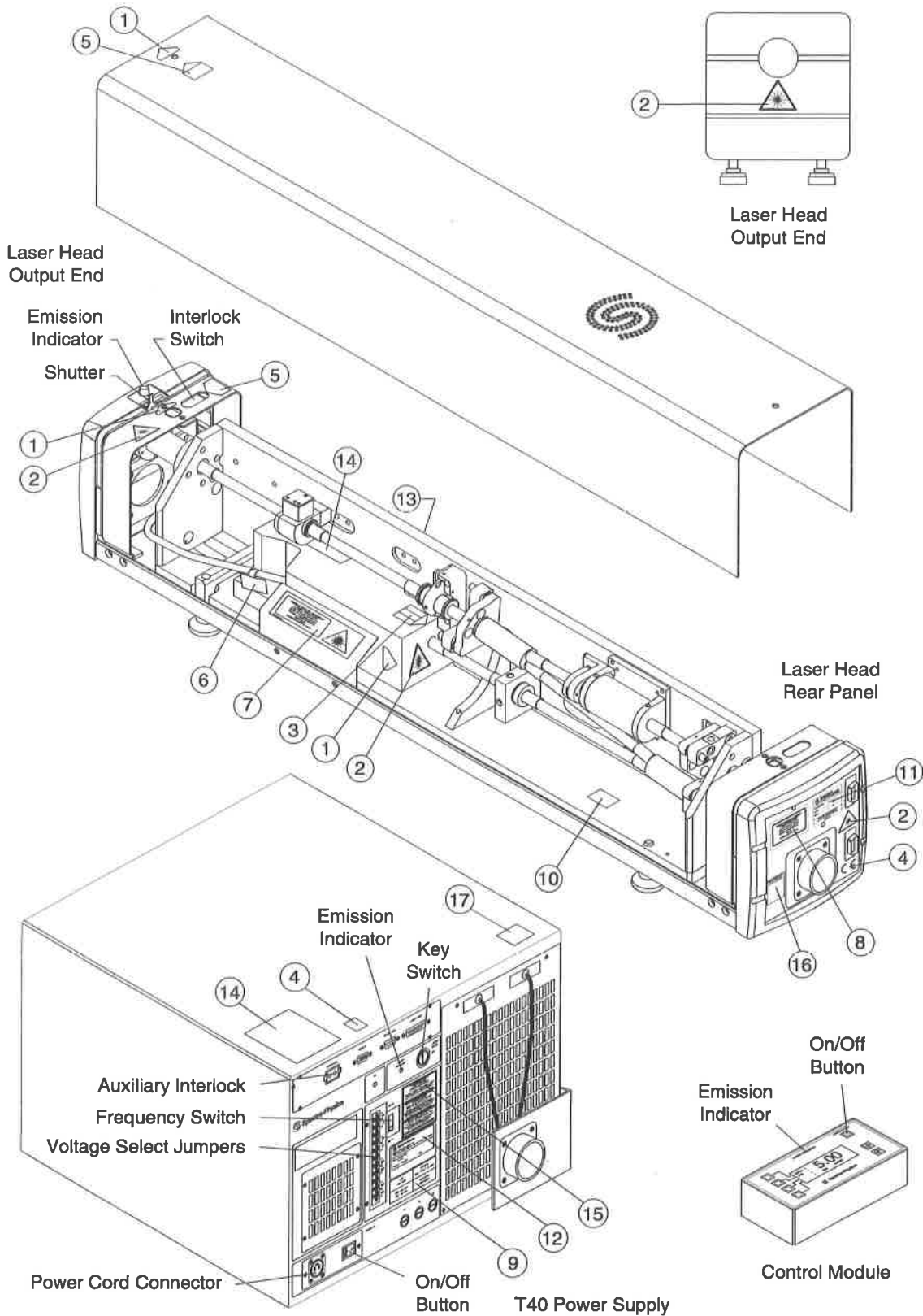



# CDRH/CE Warning Labels



CDRH Aperture Label (1)



CE Aperture Label (2)



CE Aperture Label Fiber-optic Cable(3)



CE Certification Label (4)



CDRH Danger Label Interlock Defeated (5)



CDRH Danger Label Fiber Cable, Side A (6)



CDRH Danger Label Fiber Cable, Side B (7)



CE Danger Label Fiber Cable (7)



CE Danger Label Laser Radiation (8)

|                                |                                 |
|--------------------------------|---------------------------------|
| LINE VOLTAGE                   | F1/F2/F3<br>3AG. TYPE T, UL198G |
| 200 - 240 VAC<br>100 - 127 VAC | 10A/10A/3A<br>15A/15A/3A        |

Fuse Label Power Supply (9)



Resonator Model/Serial Identification Label (10)

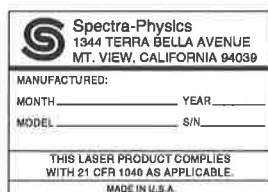

Laser Head Model/Serial Identification Label (11)

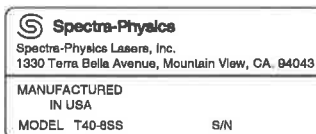

Power Supply Model/Serial Identification Label (12)

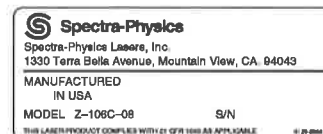

Z-Head Model/Serial Identification Label (13)



CE Warning Label Interlock Defeated (14)



CE Warning Label (15)

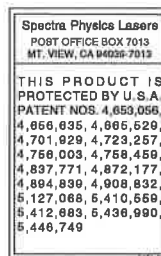

Patent Label Laser Head (16)

| U.S. PATENT NUMBERS |           |           |
|---------------------|-----------|-----------|
| 4,865,529           | 4,872,177 | 5,127,068 |
| 4,894,839           | 4,908,832 | 4,908,832 |
| 4,865,835           | 4,789,489 | 4,789,827 |
| 4,701,829           | 4,857,771 | 5,127,068 |
| 4,750,003           | 4,800,888 | 5,127,068 |
| 4,750,003           | 4,894,839 | 5,436,990 |
| 4,791,768           | 5,085,708 | 5,446,749 |

Patent Label Power Supply (17)

## EC Declaration of Conformity

We,

Spectra-Physics Lasers, Inc.  
Industrial and Scientific Lasers  
1330 Terra Bella Avenue  
P.O. Box 7013  
Mountain View, CA. 94039-7013  
United States of America

declare under sole responsibility that the:

**Millennia V Diode Pumped Solid State Laser System with Model T40-8SS  
power supply, control module, and Neslab CFT-25,**

**Manufactured after December 31, 1996**

meets the intent of "Directive 89/336/EEC for Electromagnetic Compatibility."

Compliance was demonstrated (Class A) to the following specifications as listed  
in the official *Journal of the European Communities*:

**EN 50081-2:1993 Emissions:**

**EN55011 Class A Radiated  
EN55011 Class A Conducted**

**EN 50082-1:1992 Immunity:**

**IEC 801-2 Electrostatic Discharge  
IEC 801-3 RF Radiated  
IEC 801-4 Fast Transients**

I, the undersigned, hereby declare that the equipment specified above conforms  
to the above Directives and Standards.



Steve Sheng  
Vice President and General Manager  
Spectra-Physics Lasers, Inc.  
Industrial and Scientific Lasers  
December 31, 1996

## EC Declaration of Conformity

We,

Spectra-Physics Lasers, Inc.  
Industrial and Scientific Lasers  
1330 Terra Bella Avenue  
P.O. Box 7013  
Mountain View, CA. 94039-7013  
United States of America

declare under sole responsibility that the

**Millennia V Diode Pumped Solid State Laser System coupled with the  
Model T40-8SS power supply and controller,**

meets the intent of "Directive 73/23/EEC, the Low Voltage directive."

Compliance was demonstrated to the following specifications as listed in the  
official *Journal of the European Communities*:

**EN 61010-1: 1993 Safety Requirements for Electrical Equipment for  
Measurement, Control and Laboratory use:**

**EN 60825-1: 1993 Safety for Laser Products.**

I, the undersigned, hereby declare that the equipment specified above conforms  
to the above Directives and Standards.



Steve Sheng  
Vice President and General Manager  
Spectra-Physics Lasers, Inc.  
Industrial and Scientific Lasers  
February 21, 1997

## Sources for Additional Information

The following are some sources for additional information on laser safety standards, safety equipment, and training.

### Laser Safety Standards

*Safe Use of Lasers* (Z136.1: 1993)  
American National Standards Institute (ANSI)  
11 West 42<sup>nd</sup> Street  
New York, NY 10036  
Tel: (212) 642-4900

Occupational Safety and Health Administration (Publication 8.1-7)  
U. S. Department of Labor  
200 Constitution Avenue N. W., Room N3647  
Washington, DC 20210  
Tel: (202) 219-8151

*A Guide for Control of Laser Hazards*  
American Conference of Governmental and  
Industrial Hygienists (ACGIH)  
1330 Kemper Meadow Drive  
Cincinnati, OH 45240  
Tel: (513) 742-2020

Compliance Engineering  
One Tech Drive  
Andover, MA 01810-2452  
Tel: (508) 681-6600 or (508) 681-6673

International Electrotechnical Commission  
IEC60825-10 TR3 Ed.1.0—Laser Safety Measurement and Instrumentation  
Tel: +41 22-919-0211  
Fax: +41 22-919-0300  
Internet: custserv@iec.ch

### Equipment and Training

*Laser Safety Guide*  
Laser Institute of America  
12424 Research Parkway, Suite 125  
Orlando, FL 32826  
Tel: (407) 380-1553

*Laser Focus World Buyer's Guide*  
Laser Focus World  
Penwell Publishing  
10 Tara Blvd., 5<sup>th</sup> Floor  
Nashua, NH 03062  
Tel: (603) 891-0123

*Lasers and Optronics Buyer's Guide*

Lasers and Optronics  
Gordon Publications  
301 Gibraltar Drive  
P.O. Box 650  
Morris Plains, NJ 07950-0650  
Tel: (201) 292-5100

*Photonics Spectra Buyer's Guide*

Photonics Spectra  
Laurin Publications  
Berkshire Common  
PO Box 4949  
Pittsfield, MA 01202-4949  
Tel: (413) 499-0514



## A Brief Review of Laser Theory

### *Emission and Absorption of Light\**

*Laser* is an acronym derived from Light Amplification by Stimulated Emission of Radiation. Thermal radiators, such as the sun, emit light in all directions, the individual photons having no definite relationship with one another. But because the laser is an oscillating amplifier of light, and because its output comprises photons that are identical in phase and direction, it is unique among light sources. Its output beam is singularly directional, monochromatic, and coherent.

Radiant emission and absorption take place within the atomic or molecular structure of materials. The contemporary model of atomic structure describes an electrically neutral system composed of a nucleus with one or more electrons bound to it. Each electron occupies a distinct orbital that represents the probability of finding the electron at a given position relative to the nucleus. Each orbital has a characteristic shape that is defined by the radial and angular dependence of that probability, e.g., all *s* orbitals are spherically symmetrical, and all *p* orbitals surround the *x*, *y*, and *z* axes of the nucleus in a double-lobed configuration (Figure 3-1). The energy of an electron is determined by the orbital that it occupies, and the over-all energy of an atom—its energy level—depends on the distribution of its electrons throughout the available orbitals. Each atom has an array of energy levels: the level with the lowest possible energy is called the ground state, and higher energy levels are called excited states. If an atom is in its ground state, it will stay there until it is excited by external forces.

Movement from one energy level to another—a transition—happens when the atom either absorbs or emits energy. Upward transitions can be caused by collision with a free electron or an excited atom, and transitions in both directions can occur as a result of interaction with a photon of light. Consider a transition from a lower level whose energy content is  $E_1$  to a higher one with energy  $E_2$ . It will only occur if the energy of the incident photon matches the energy difference between levels, i.e.,

$$h\nu = E_2 - E_1 \quad [1]$$

where  $h$  is Planck's constant, and  $\nu$  is the frequency of the photon.

\* "Light" will be used to describe the portion of the electromagnetic spectrum from far infrared to ultraviolet.

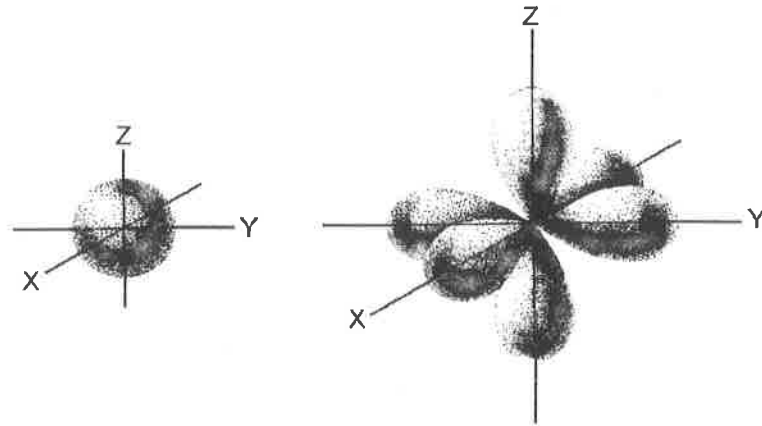

**Figure 3-1: Electrons occupy distinct orbitals that are defined by the probability of finding an electron at a given position, the shape of the orbital being determined by the radial and angular dependence of the probability.**

Likewise, when an atom excited to  $E_2$  decays to  $E_1$ , it loses energy equal to  $E_2 - E_1$ . The atom may decay spontaneously, emitting a photon with energy  $h\nu$  and frequency

$$\nu = \frac{E_2 - E_1}{h} \quad [2]$$

Spontaneous decay can also occur without emission of a photon, the lost energy taking another form, e.g., transfer of kinetic energy by collision with another atom. An atom excited to  $E_2$  can also be stimulated to decay to  $E_1$  by interacting with a photon of frequency  $\nu$ , emitting energy in the form of a pair of photons that are identical to the incident one in phase, frequency, and direction. This is known as stimulated emission. By contrast, spontaneous emission produces photons that have no directional or phase relationship with one another.

A laser is designed to take advantage of absorption, and both spontaneous and stimulated emission phenomena, using them to create conditions favorable to light amplification. The following paragraphs describe these conditions.

### **Population Inversion**

The net absorption at a given frequency is the difference between the rates of emission and absorption at that frequency. It can be shown that the rate of excitation from  $E_1$  to  $E_2$  is proportional to both the number of atoms in the lower level ( $N_1$ ) and the transition probability. Similarly, the rate of stimulated emission is proportional to the population of the upper level ( $N_2$ ) and the transition probability. Moreover, the transition probability depends on the flux of the incident wave and a characteristic of the transition called its "cross section." The absorption coefficient depends only on the difference between the populations involved,  $N_1$  and  $N_2$ , and the flux of the incident wave.



When a material is at thermal equilibrium, there exists a Boltzmann distribution of its atoms over the array of available energy levels with most atoms in the ground state. Since the rate of absorption of all frequencies exceeds that of emission, the absorption coefficient at any frequency is positive.

If enough light of frequency  $\nu$  is supplied, the populations can be shifted until  $N_1 = N_2$ . Under these conditions the rates of absorption and stimulated emission are equal, and the absorption coefficient at frequency  $\nu$  is zero. If the transition scheme is limited to two energy levels, it is impossible to drive the populations involved beyond equality; that is,  $N_2$  can never exceed  $N_1$  because every upward transition is matched by one in the opposite direction.

However, if three or more energy levels are employed, and if their relationship satisfies certain requirements described below, additional excitation can create a population inversion where  $N_2 > N_1$ .

A model four-level laser transition scheme is depicted in Figure 3-2. A photon of frequency  $\nu_1$  excites—or “pumps”—an atom from  $E_1$  to  $E_4$ . If the  $E_4$  to  $E_3$  transition probability is greater than that of  $E_4$  to  $E_1$ , and if the lifetime of an atom at  $E_4$  is short, the atom will decay almost immediately to  $E_3$ . If  $E_3$  is metastable, i.e., atoms that occupy it have a relatively long lifetime, the population will grow rapidly as excited atoms cascade from above. The  $E_3$  atom will eventually decay to  $E_2$ , emitting a photon of frequency  $\nu_2$ . Finally, if  $E_2$  is unstable, its atoms will rapidly return to the ground state,  $E_1$ , keeping the population of  $E_2$  small and reducing the rate of absorption of  $\nu_2$ . In this way the population of  $E_3$  is kept large and that of  $E_2$  remains low, thus establishing a population inversion between  $E_3$  and  $E_2$ . Under these conditions, the absorption coefficient at  $\nu_2$  becomes negative. Light is amplified as it passes through the material, which is now called an “active medium.” The greater the population inversion, the greater the gain.

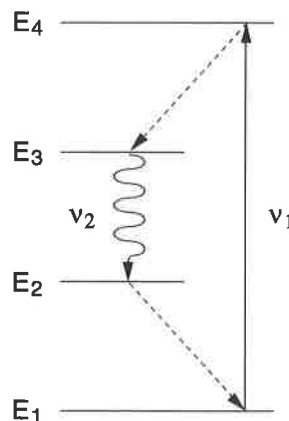

**Figure 3-2: A Typical Four-level Transition Scheme**

A four-level scheme has a distinct advantage over three-level systems, where  $E_1$  is both the origin of the pumping transition and the terminus of the lasing transition. Also, the first atom that is pumped contributes to the

population inversion in the four-level arrangement, while over half of the atoms must be pumped from  $E_1$  before an inversion is established in the three-level system.

### Resonant Optical Cavity

To sustain lasing action, the gain medium must be placed in a resonant optical cavity. The latter can be defined by two mirrors which provide feedback to the active medium, i.e., photons emitted parallel to the cavity axis are reflected back into the cavity to interact with other excited states. Stimulated emission produces two photons of equal energy, phase, and direction from each interaction. The two photons become four, four become eight, and the numbers continue to increase geometrically until an equilibrium between excitation and emission is reached.

Both cavity mirrors are coated to reflect the wavelength, or wavelengths, of interest while transmitting all others. One of the mirrors, the output coupler, transmits a fraction of the energy stored within the cavity, and the escaping radiation becomes the output beam of the laser.

The laser oscillates within a narrow range of frequencies around the transition frequency. The width of the frequency distribution, the “linewidth,” and its amplitude depend on the gain medium, its temperature, and the magnitude of the population inversion.

Linewidth is determined by plotting gain as a function of frequency and measuring the width of the curve where the gain has fallen to one half maximum (“full width at half maximum”, or FWHM, Figure 3-3).

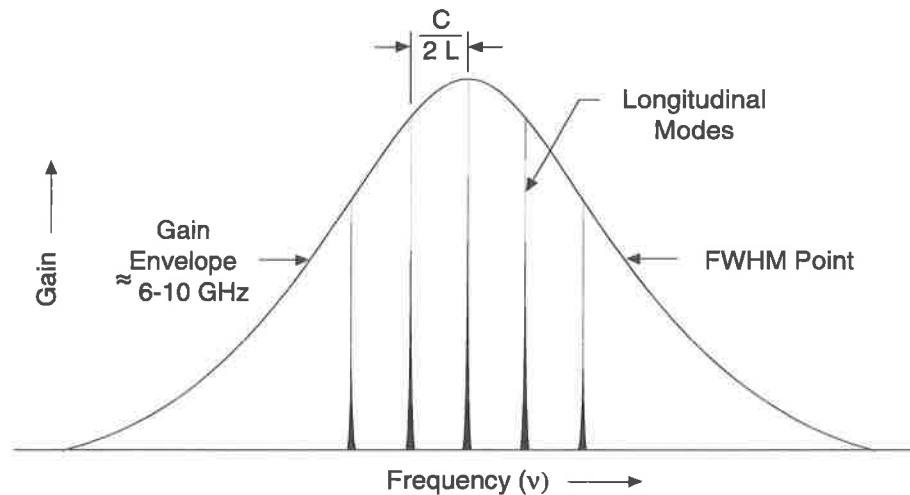

**Figure 3-3: Frequency Distribution of Longitudinal Modes for a Single Line**

The output of the laser is discontinuous within this line profile. A standing wave propagates within the optical cavity, and any frequency that satisfies the resonance condition

$$\nu_m = \frac{mc}{2L} \tag{3}$$

will oscillate, where  $\nu_m$  is the frequency,  $c$  is the speed of light,  $L$  is the optical cavity length, and  $m$  is an integer. Thus, the output of a given line is a set of discrete frequencies, called "longitudinal modes," that are spaced such that

$$\Delta\nu = \frac{c}{2L} \quad [4]$$

### $\text{Nd}^{3+}$ as a Laser Medium

In commercial laser designs, the source of excitation energy for the gain medium is usually optical or electrical. Arc lamps are often employed to pump solid-state lasers, and the output of one laser can be used to pump another, e.g., a Ti:sapphire laser can be pumped by an argon ion laser or a diode laser can be used to pump a solid state laser. An electric discharge is generally used to excite gaseous media like argon or krypton. The Millennia V uses the output from a diode laser to pump  $\text{Nd}^{3+}$  ions doped in a yttrium vanadate crystalline matrix ( $\text{Nd:YVO}_4$ ).

The properties of neodymium-doped matrices, such as yttrium aluminum garnet ( $\text{Nd:YAG}$ ) and yttrium lithium fluoride ( $\text{Nd:YLF}$ ), are the most widely studied and best understood of all solid-state laser media. The four-level  $\text{Nd}^{3+}$  ion scheme is shown in Figure 3-4. The active medium is triply ionized neodymium which has principle absorption bands in the red and near infrared. Excited electrons quickly drop to the  $^4F_{3/2}$  level, the upper level of the lasing transition, where they remain for a relatively long time (about 60  $\mu\text{s}$  for  $\text{Nd:YVO}_4$ ).

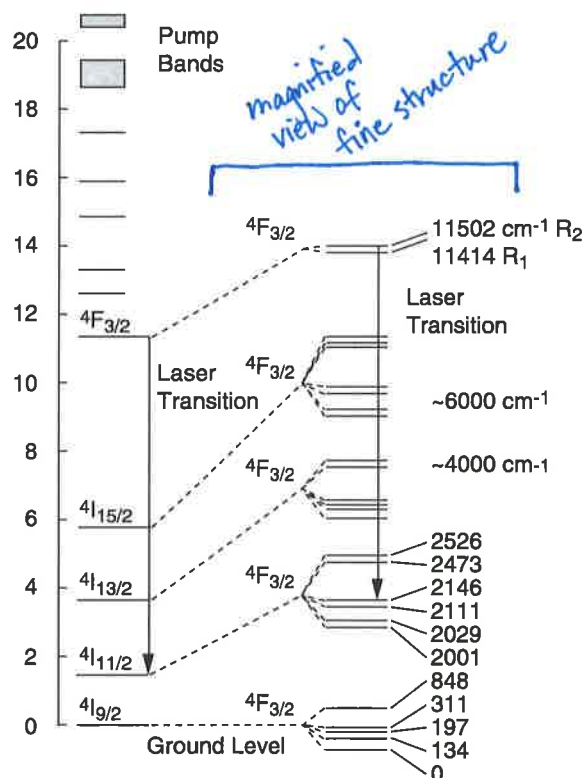
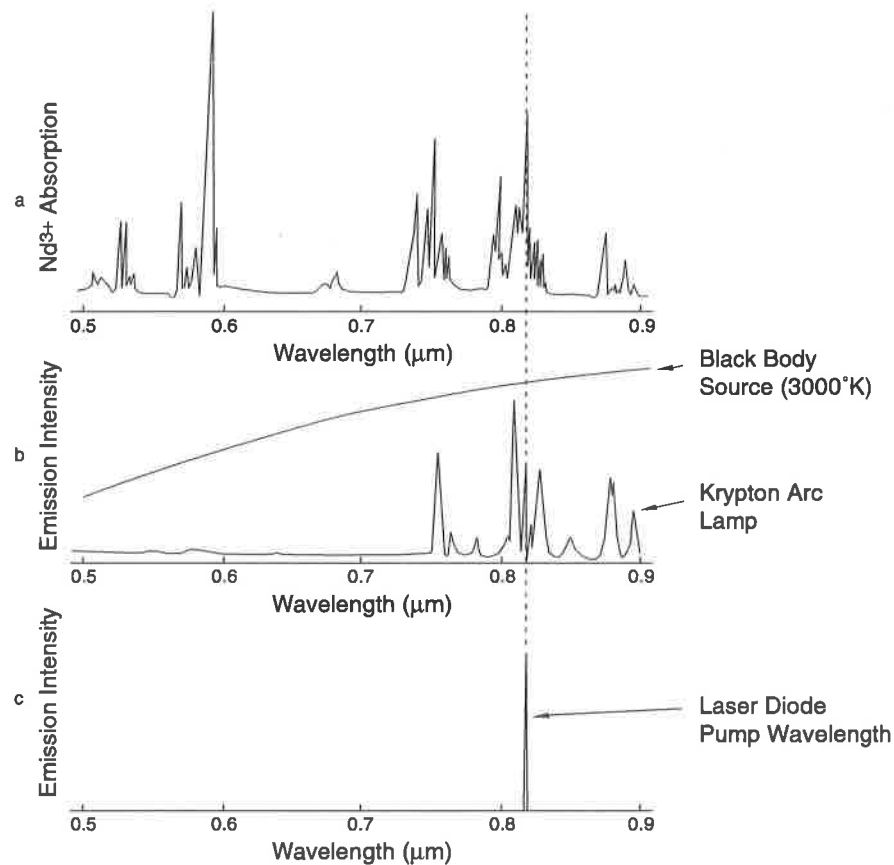

Figure 3-4: Energy Level Scheme for the  $\text{Nd}^{3+}$  Ion.

The most probable lasing transition is to the  $^4I_{1/2}$  state, where a photon at 1064 nm is emitted. Because electrons in that state quickly relax to the ground state, its population remains low. Hence, it is easy to build a population inversion. At room temperature the emission cross section of this transition is high, so its lasing threshold is low. While there are competing transitions from the same upper state, most notably at 1319, 1338, and 946 nm, all have lower gain and a higher threshold than the 1064 nm transition. In normal operation, these factors and wavelength-selective optics limit oscillation to 1064 nm.

**Diode-pumped Laser Design**

Laser diodes combine very high brightness, high efficiency, monochromaticity and compact size in a near-ideal source for pumping solid-state lasers. Figure 3-5 shows the monochromaticity of the emission spectra of a laser diode compared to a krypton arc lamp and a black body source and compares that with the absorption spectra of the  $Nd^{3+}$  ion. The near-perfect overlap of the diode laser output with the  $Nd^{3+}$  absorption band ensures that the pump light is efficiently coupled into the laser medium. It also reduces thermal loading since any pump light *not* coupled into the medium is ultimately removed as heat.



**Figure 3-5:  $Nd^{3+}$  absorption spectra compared to emission spectra of a Black Body Source (a), Krypton Arc Lamp (b) and a Laser Pump Diode (c).**

One of the key elements in optimizing the efficiency of a solid-state laser is maximizing the overlap of the regions of the active medium excited by the pumping source and the active medium occupied by the laser mode. The maximization of this overlap is often called mode matching, and in most applications,  $TEM_{00}$  is the laser mode that is most desired. A longitudinal pumping geometry provides this sort of optimal mode-match.

Longitudinal pumping allows the diode output to be focused on a volume in the active medium that best matches the radius of the  $TEM_{00}$  mode. In general, the  $TEM_{00}$  mode radius is chosen to be as small as possible to minimize the solid-state laser threshold. Figure 3-6 shows a schematic of a mode-matching design of this type.

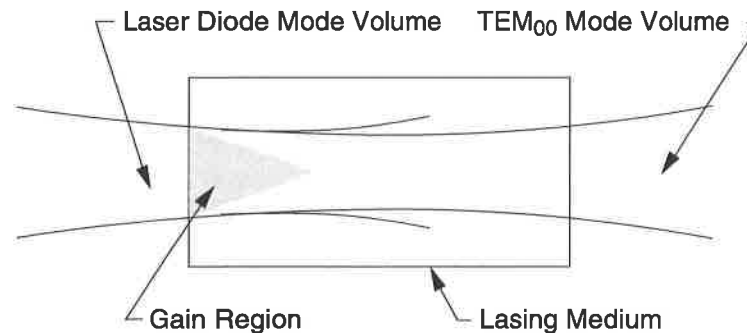

**Figure 3-6: Mode Matching**

For higher output power levels, a larger laser diode having a larger emission region is necessary. The diameter of the  $TEM_{00}$  mode volume must also be expanded to effectively mode-match the volume of the extended diode emission region. However, increasing the  $TEM_{00}$  mode volume raises the solid-state laser threshold. This is undesirable when attempting to create an efficient laser diode design.

At Spectra-Physics, we use laser diode bars made from a single monolithic piece of semiconductor material which typically contains ten to twenty laser diodes. The bars are ideal as high power pump sources. These devices have the same high efficiency as the discrete diode devices, yet they allow for the manufacture of a much simpler and more reliable high-power pump laser design than is possible in a design incorporating an equal number of discrete devices (for the same output power level). However, the active emission area for these new devices is increased from the 200  $\mu\text{m}$  range found in low power diodes, to 1 cm: a “ribbon of light.” The use of these bars has, therefore, been limited due to the difficulty of mode matching their outputs.

A number of attempts were recently made by some manufacturers to couple the output of a laser diode bar into a multimode optical fiber. The results have been discouraging, so far, with coupling efficiencies on the order of 60–70% with a numerical aperture of 0.4. This makes for an expensive, inefficient pump source.

At Spectra-Physics, we have developed and patented a vastly more efficient method of fiber coupling the output of the laser diode bar. It is called FCbar™. With this method, it is possible to achieve coupling efficiencies in excess of 90% with a numerical aperture of 0.1. With such high coupling efficiency and brightness, high power diode-pumped laser designs are readily achieved.

## Frequency Doubling

In the Millennia V, the high output power from the laser diodes is used to end-pump the Nd:YVO<sub>4</sub> lasing medium. The resulting 1064 nm output is converted to the visible through frequency doubling or second harmonic generation in a nonlinear crystal. The Millennia V uses a 90°, non-critically phase-matched, temperature-tuned lithium triborate (LBO) nonlinear crystal as its doubling medium. Although LBO has a lower nonlinear coefficient than other materials, it offers several advantages: (a) non-critical phase matching means collinear fundamental and second harmonic beams which facilitates alignment, (b) there is no spatial “walk-off” of the fundamental and second harmonic beams, which preserves the high spatial mode quality and favors a long interaction length for higher gain, and (c) the crystal can be easily optimized for maximum conversion efficiency by simply changing its temperature (with no realignment of the laser cavity).

In frequency doubling, the second harmonic power ( $P_{2\omega}$ ) is given by:

$$P_{2\omega} \propto \frac{d_{eff}^2 P_{\omega}^2 l^2 [\phi]}{A} \quad [5]$$

where  $d_{eff}$  is the effective nonlinear coefficient,  $P_{\omega}$  is the fundamental input power,  $l$  is the effective crystal length,  $[\phi]$  is a phase-matching factor, and  $A$  is the cross-sectional area of the beam in the crystal. Since the second harmonic output is dependent upon the square of the fundamental peak power, very high conversion efficiencies can be achieved by enhancing the intensity of the fundamental wave through intracavity frequency doubling or through the use of an external-cavity resonant-doubler. The former is used in the Millennia V.

Historically, free-running intracavity-doubled diode-pumped solid state lasers have typically yielded chaotic output with large amplitude fluctuations that render the laser output useless for most scientific applications. This was first identified at Spectra-Physics<sup>1</sup> over ten years ago in a short cavity diode-pumped Nd:YAG laser with a KTP intracavity doubler; it has since become known as the “green problem.” Part of the cause of the instability arises from nonlinear coupling of axial modes via sum-frequency mixing in the laser cavity. The problem can be circumvented by forcing oscillation on a single longitudinal mode. However, this adds considerable complexity to the laser, since it requires an actively stabilized ring cavity (and it may also have power limitations). The Millennia V overcomes this chaotic noise problem with the simple, patented, QMAD (quiet multiaxial mode doubling) solution, which makes use of many axial modes (see Figure 3-7).

<sup>1</sup> T. Baer. *J. Opt. Soc. Am. B3*, 1175 (1986).

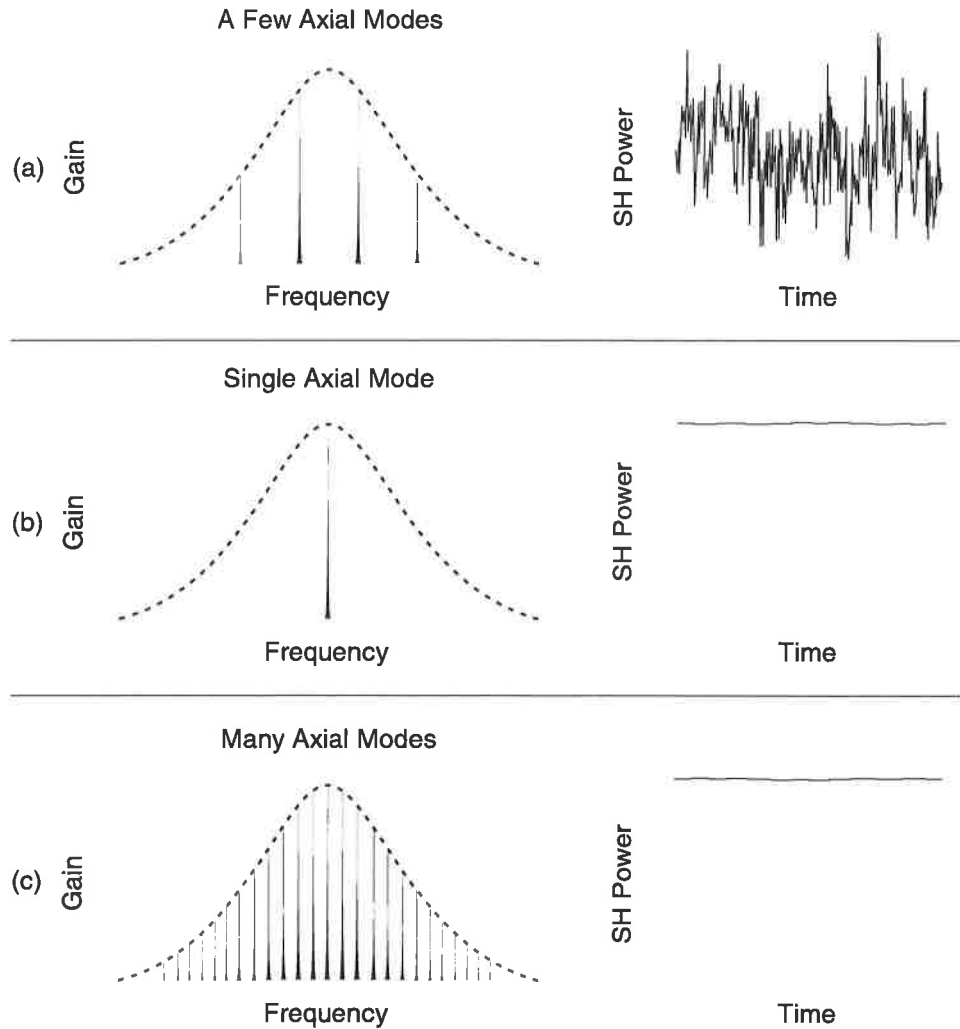

**Figure 3-7: The quiet multi-axial mode-doubling (QMAD) solution to the “green problem.” (a) The “green problem.” Intracavity frequency doubling in a laser with a few axial modes produces large amplitude fluctuations in the second harmonic output resulting from nonlinear coupling of the modes through sum-frequency mixing. (b) The single-frequency solution forces oscillation on a single axial mode to eliminate mode coupling. (c) The QMAD solution produces oscillation on many axial modes, effectively averaging the nonlinear coupling terms to provide highly stable second-harmonic output.**

In the Millennia V, the laser cavity is stretched to about 1 meter to allow oscillation of over 100 longitudinal modes. This facilitates quiet intracavity doubling by reducing the relative power in each axial mode so that no one mode reaches sufficient peak power to induce high nonlinear loss. Effectively, there is an averaging of the nonlinear coupling terms and the resultant frequency-doubled output exhibits extremely low amplitude noise (about an order of magnitude lower than that of an ion laser).

## The Millennia™ V System

The Millennia V system comprises four basic components:

- Millennia V laser head
- T40 power supply
- Chiller
- Control Module

The following sections will be confined to descriptions of the laser head and power supply. The control module is fully described in Chapter 6, "Operation," and the chiller is fully described in the User's Manual shipped with that unit.

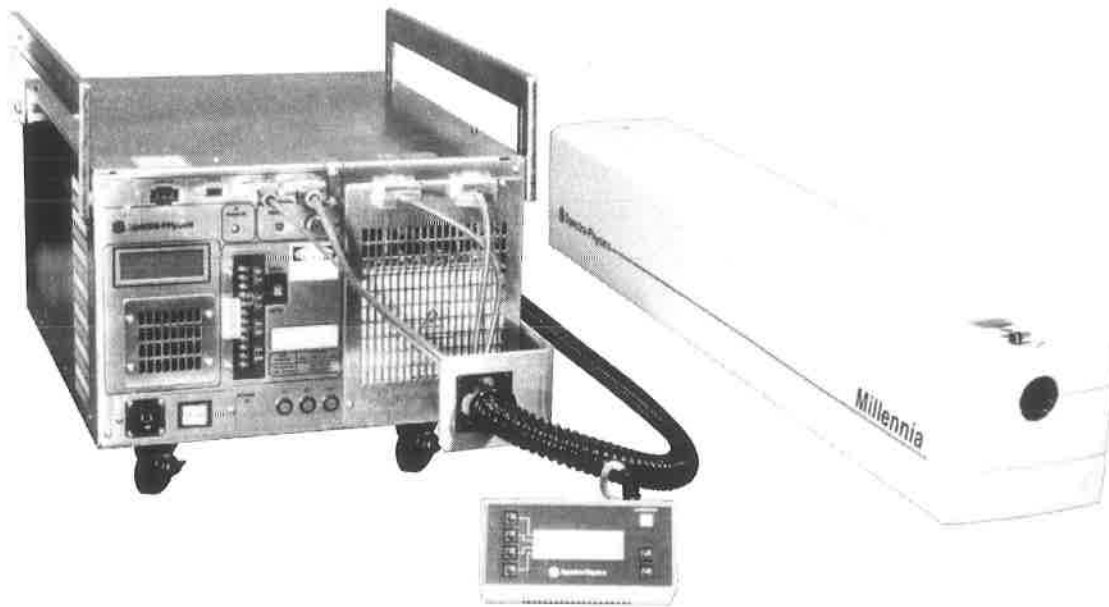

Figure 3-8: The Millennia V System (chiller not shown)

### Overview

In the Millennia V laser head, the output from two high-power, fiber-coupled laser diode bars (**FCbar**) is used to end-pump the laser gain medium, a neodymium yttrium vanadate (Nd:YVO<sub>4</sub>) crystal (see Figure 3-10). The **FCbar** design allows the diode bars to be placed in the power supply, which removes their heat load from the laser head and facilitates their field replacement because realignment of the Millennia V cavity is not required.



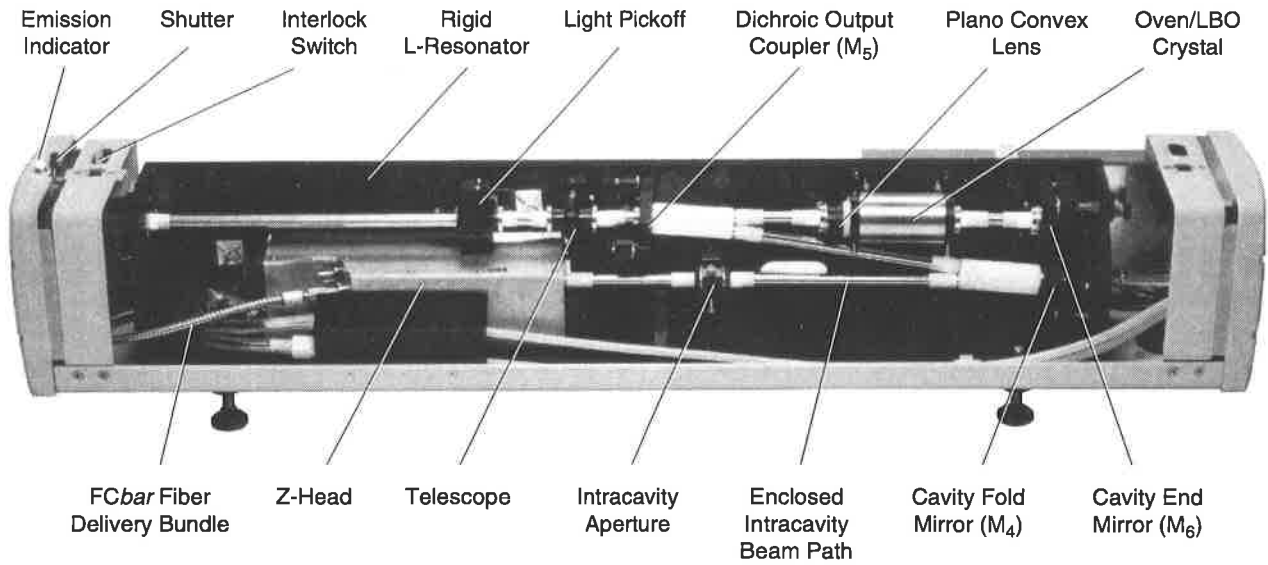

Figure 3-9: The Millennium V Laser Head

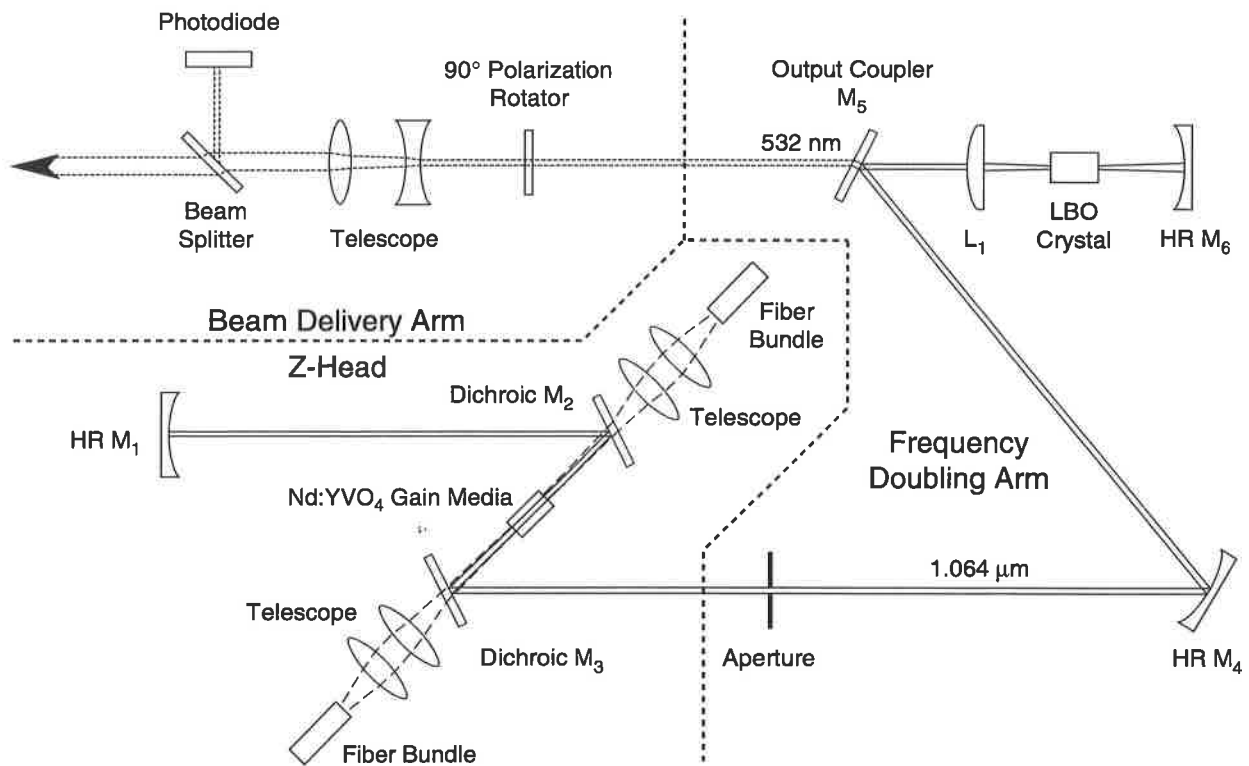

Figure 3-10: Schematic of the Millennium V Laser Head

Telescopes are used to focus the pump light through dichroic fold mirrors M<sub>2</sub> and M<sub>3</sub> and into the laser crystal where 1064 nm infrared intracavity light is generated. M<sub>2</sub> and M<sub>3</sub> are highly transmissive at the diode pump wavelength and highly reflective at 1064 nm. The aperture maintains the intracavity beam at a size that is optimal for beam overlap in the Nd:YVO<sub>4</sub> crystal, thus ensuring efficient cavity light generation in the TEM<sub>00</sub> mode.

A non-critically phase-matched lithium triborate (LBO) crystal placed in the cavity near the high reflector mirror  $M_6$  converts the intracavity light to the green 532 nm wavelength. The patented Quiet Multi-Axial Mode Doubling (QMAD) technique provides exceptionally low-noise performance. It uses a very large number of axial modes and balances gain, nonlinear conversion, and excited-state lifetime to provide high power and extremely stable amplitude.

Virtually all the doubled light passes through the dichroic output coupler  $M_5$  where the beam is then expanded and directed out of the laser. A beam splitter and photodiode sample the output and provide feedback to the pump diode drivers to provide a constant output in power mode operation.

## The Millennia V Laser Head

The laser head is designed for maximum reliability with minimum complexity. All resonator components are rigidly attached to a solid L-shaped resonator, and the entire intracavity beam path is enclosed for maximum stability and prolonged hands-off operation. The inherent operation is so stable and the output so quiet that no adjustments are needed for normal operation. Control of the entire system is provided via a simple, menu-driven control module.

Three major components comprise the laser head (Figure 3-10):

- Z-head
- Frequency doubling arm
- Beam delivery arm

### The Z-head

The Z-head is a compact, fully enclosed module that is so named for the beam path within it (see Figure 3-11). It contains the neodymium yttrium vanadate ( $\text{Nd:YVO}_4$ ) laser crystal which is the “driving engine” of the Millennia V laser. The crystal is end-pumped by two fiber-coupled diode bar (FCbar) modules and provides a very high cw, small signal gain. It is capable of producing over 10 W of near diffraction-limited, 1064 nm infra-red power with a conversion efficiency greater than 50%.

As shown in the figure, the outputs from the two pump diode modules in the power supply are fiber-coupled into the Z-head and focused into each end of the  $\text{Nd:YVO}_4$  laser crystal. The diode pump light is absorbed by the crystal and emitted as output at 1064 nm. The 1064 nm output is resonated in the Millennia V cavity and amplified through stimulated emission.

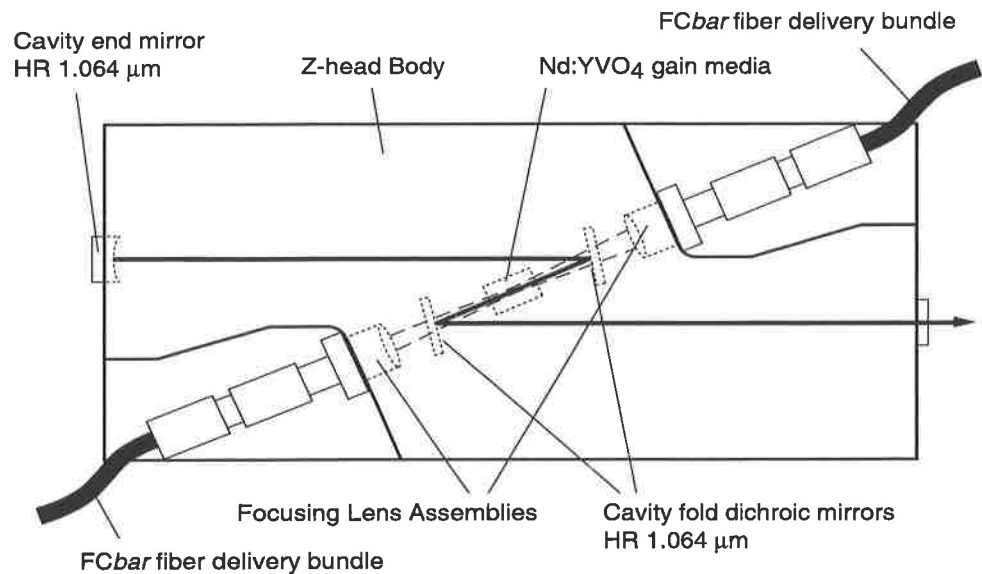

**Figure 3-11: The Z-Head (top view)**

### ***The Frequency Doubling Arm***

As its name implies, the frequency-doubling arm (Figure 3-10) converts the 1064 nm light from the laser crystal to the green 532 nm light that becomes the output of the laser.

For maximum intracavity frequency doubling conversion efficiency, a non-critically phase-matched, temperature-tuned LBO crystal is used. It offers a large acceptance angle, which makes it insensitive to any slight misalignment of the Millennium V cavity. A small, low-power, temperature-regulating oven is used to maintain the crystal at the appropriate phase-matching temperature to keep the 532 nm power optimized.

QMAD (Quiet Multiaxial Mode Doubling) technology (patent number 5,446,749) allows the Millennium V to provide greater than 5 watts of exceptionally stable, low-noise, frequency-doubled light. It provides a stable balance of:

- a very large number of axial modes (typically hundreds),
- small signal gain,
- gain saturation,
- nonlinear conversion,
- excited state lifetime, and
- cavity lifetime

to enable the Millennium V to use intracavity doubling with the simplicity of a single linear cavity design. The result is a high-power, multi-axial-mode laser that exhibits extremely low noise performance with very high reliability, and a doubled beam that has a smooth intensity distribution and is near diffraction limited.

## **The Beam Delivery Arm**

The beam delivery arm (Figure 3-10) controls the output beam parameters and modifies it to resemble that of a small-frame ion laser. A dichroic output coupler allows the 532 nm light to exit the cavity while reflecting the 1064 nm light back into the cavity. The 90° polarization rotator aligns the polarization axis vertically to match that of most small-frame argon ion lasers. A telescope expands the 532 nm output beam to match the beam size and propagation parameters to those of an argon ion laser. This ensures optimum performance when the Millennia V is used to pump a Spectra-Physics Tsunami mode-locked Ti:sapphire laser, a Model 3900S cw Ti:sapphire laser, or a Model 375B dye laser.

Unlike other systems that require multiple feedback loops to maintain stable output, the Millennia V is inherently stable within its operating range. It requires only one simple feedback loop to maintain its exceptional performance and maintain constant output power. The light pick-off is an integral part of the output telescope system.

## **The T40 Power Supply**

### **FCbar**

The pump source for the Millennia V laser head consists of two diode laser bars, each module capable of producing 20 W. The two modules are then coupled to optical fiber bundles that transport the diodes' output to each end of the laser crystal in the Z-head. This modular concept is called a "fiber-coupled bar" or **FCbar**<sup>TM</sup>.

### **The FCbar System**

**FCbar** technology enables the high power levels available from the laser diode bars to efficiently end-pump the Nd:YVO<sub>4</sub> laser crystal. This is done by first collimating the output of the bar with a cylindrical microlens of high numerical aperture (the microlens is bonded to the diode bar in order to reduce the fast-axis divergence of the diode bar). The highly asymmetric light is then coupled into a fiber bundle, which in turn delivers exceptional brightness to the crystal. To stabilize the output wavelength of the diodes, the modules are mounted directly on a temperature regulated cold plate.

Because the coupling technology is so efficient, the 20 W diode modules are typically derated 75% to increase their operating lifetime.

The multimode optical fiber bundle is actually several fibers that are drawn together in a round bundle where the output end is typically 1 to 1.5 mm in diameter with a numerical aperture of about 0.1. Typically, 85 to 90 percent of the diode light is transmitted by the bundle; thus, up to 13 W of usable output is available from each derated laser diode bar at the output of the fiber bundle.

The **FCbar** modules mate with the fiber bundle through precision connections that are assembled and aligned at the factory. The bundles are then

terminated at the Z-head with industry standard fiber-optic connectors. This provides a precise and repeatable attachment of the bundle to the Z-head and allows the **FCbar** modules to be replaced in the field, if necessary, without requiring a major realignment.

## Specifications

**Table 3-1: Millennia V Specifications**

### Laser Output Characteristics<sup>1</sup>

|  |                   |
|--|-------------------|
| <b>Power</b>   | 5 W               |
| <b>Wavelength</b>  | 532 nm            |
| <b>Spatial Mode<sup>2</sup></b>                            | TEM <sub>00</sub> |
| <b>Beam diameter at 1/e<sup>2</sup> points<sup>3</sup></b> | <2.5 mm           |
| <b>Beam divergence, full angle</b>                         | <0.5 mrad         |
| <b>Polarization</b>  | >100:1, vertical  |
| <b>Power Stability<sup>4</sup></b>                         | ±1.0%             |
| <b>Beam Pointing Stability<sup>5</sup></b>                 | <5 µrad/°C        |
| <b>Noise<sup>6</sup></b>                                   | <0.1% rms         |

<sup>1</sup> Specifications subject to change without notice.

<sup>2</sup>  $M^2 < 1.1$ ; Beam ellipticity <10%.

<sup>3</sup> Measured at the exit port.

<sup>4</sup> Measured over a 2 hour period after a 30 minute warm-up, from standby mode.

<sup>5</sup> Measured as far-field x and y positions, after a 30 minute warm-up, from standby mode.

<sup>6</sup> Measured over a 10 Hz to 10 MHz bandwidth at the specified output power.

### Power Requirements

|                     |   |
|---------------------|---|
| <b>Power Supply</b> | 110 Vac ±10% at <10 A, 60 Hz<br>220 Vac ±10% at <6 A, 50 Hz |
| <b>Chiller</b>      | 110 Vac ±10% at 10 A, 60 Hz<br>220 Vac ±10% at 6 A, 50 Hz   |

### Fuse Requirements

| <b>Voltage</b> | <b>Fuse (Type 3AG)<br/>F<sub>1</sub> / F<sub>2</sub> / F<sub>3</sub></b> |
|----------------|--|
| 200 – 240 Vac  | 10 A / 10 A / 3 A  |
| 100 – 127 Vac  | 15 A / 15 A / 3 A  |

## Dimensions

---

### Laser Head

**Size**

91.5 L x 15.2 W x 17.4 H cm  
(36.0 L x 6.0 W x 6.8 H in.)

**Weight**

13.9 kg (30.5 lb)

**Umbilical Length**

3.35 m (11 ft)

**Controller Cable Length**

2.44 m (8 ft)

---

### Power Supply

**Size**

64 L x 41 W x 33 H cm\*  
(25 L x 16 W x 13 H in.\*)

**Weight**

50.1kg (110 lb)

**Power Cable Length**

2.44 m (8 ft)

---

### Chiller

**Size**

55.9 L x 31.8 W x 56.5 H cm  
(22.0 L x 12.5 W x 22.3 H in.)

**Weight**

59.9 kg (132 lb)

---

\* With casters, add 6.9 cm or 2.7 in.

## Outline Drawings

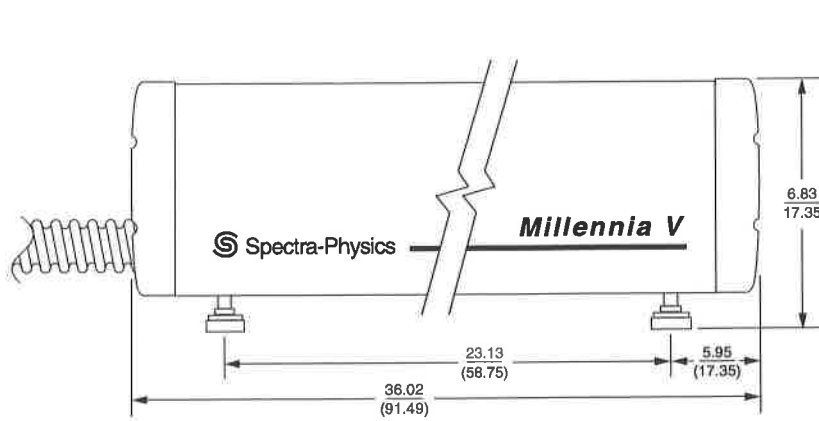

Millennia V Side View

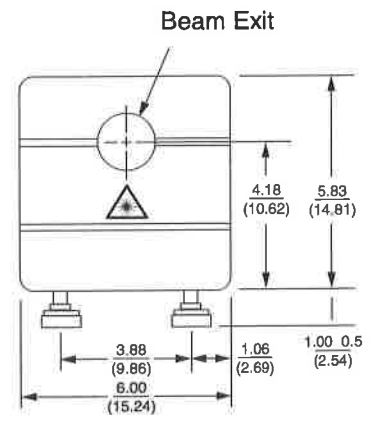

Millennia V Output End

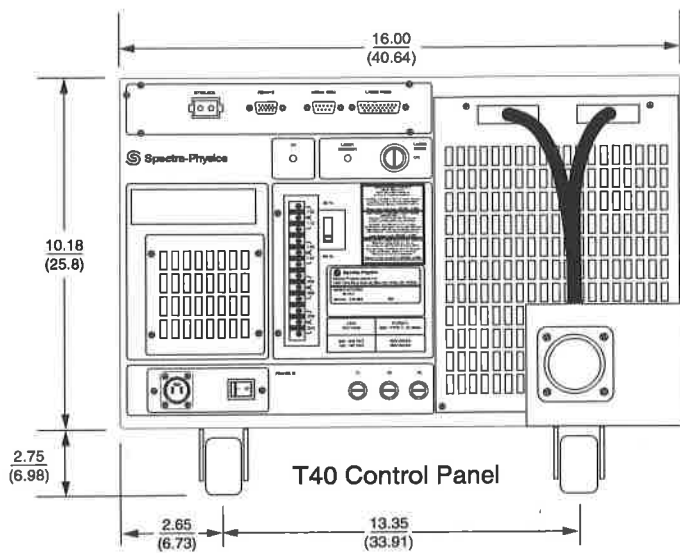

T40 Control Panel

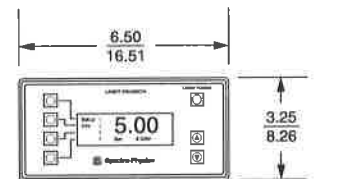

Controller Top View



Controller Side View

All dimensions in  $\frac{\text{inches}}{\text{cm}}$

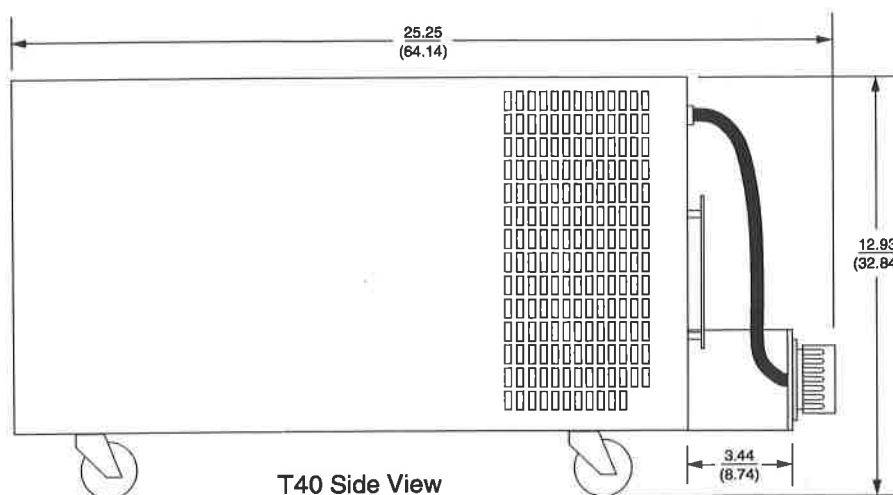

T40 Side View





## Introduction

This section defines the user controls, indicators and connections of the Millennia™ V laser system. It is divided into three sections: the Millennia V laser head, the Millennia V control module and the T40 power supply. Information on the chiller can be found in the user's manual that accompanies it.

Figure 4-1 shows the location of the various components in the Millennia V laser head.

## Laser Head Controls

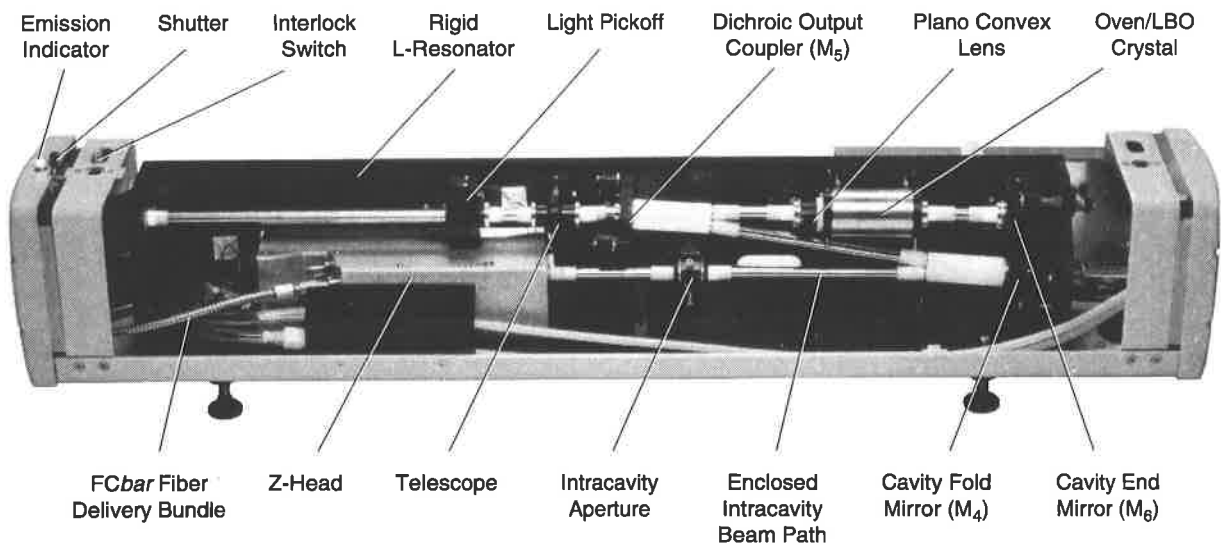

**Figure 4-1: The Millennia V Laser Head**

## External Controls

**Shutter**—blocks the output beam when the lever is moved to the blocking position (Ø). The lever is located near the emission indicator on top of the output bezel. It is accessible when the cover is on.

**Cover clamping screws (2)**—hold the cover securely in place. One screw is located on top of the cover at each end of the laser. Use the Allen drivers provided to fasten and unfasten the ¼ turn screws.

**Foot height adjustments (4)**—provide a means to level the laser and to adjust its height to match that of the target device. The legs are large screws with swivel feet that can be screwed up and down from inside the laser head using an Allen driver. Once the height adjustment has been made, a jam nut on each leg is tightened up against the chassis to lock them in place.

### Internal Controls

**Warning!**



---

*NEVER* adjust any internal controls other than those listed here. Doing so will require a major realignment that can only be performed at the factory. Such an alignment is not covered by your warranty and you will be charged accordingly.

---

**Interlock switch**—shuts the laser off immediately when the cover is removed. The switch is located behind the shutter near the output bezel. It can be defeated using the yellow plastic “T”-shaped key that is clamped to the vertical resonator plate near the switch. To defeat the switch, insert the key in the slot and press the key down against the spring, then rotate it 90° clockwise to lock it in place. To remove it, rotate it 90° counterclockwise and lift it out.

While the key is in the defeat position, the cover cannot be installed.

**Vertical high reflector adjust (M<sub>6</sub>)**—provides vertical adjustment for power optimization. It is recessed behind the rear bezel (Figure 4-2), but it can be accessed using one of the large-handled Allen drivers provided.

**Horizontal high reflector adjust (M<sub>6</sub>)**—provides horizontal adjustment for power optimization. It is recessed behind the rear bezel (Figure 4-2), but it can be accessed using one of the large-handled Allen drivers provided.

### Indicators

There is only one indicator on the laser head:

**Emission indicator light**—warns of present or imminent laser radiation. This white-light CDRH indicator is located at the top center of the output bezel. A built-in delay between the turn on of the lamp and actual emission allows for evasive action in the event the system was started by mistake.

## Connections

There are three connections on the Millennium V rear panel (Figure 4-2): the permanently attached umbilical cable from the power supply, the 9-pin RS-232 serial port, and the 15-pin Millennium V controller connector.

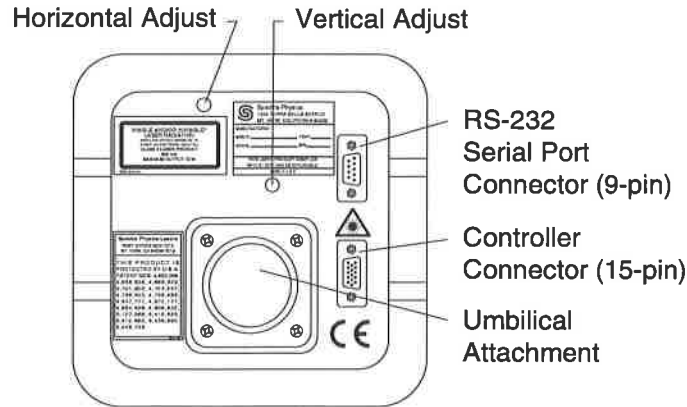

**Figure 4-2: The Millennium V Laser Head Rear Panel**

**Umbilical connector**—provides control signals to and from the power supply, cooling water from the chiller, and laser output from the diodes. *This umbilical is permanently attached: do not try to remove it.* To move the laser system, disconnect the chiller supply lines at the chiller and drain the lines, then set the laser head and the controller on top of the power supply and roll the system to its new location. Make sure the cooling lines are reconnected and tightly fastened before you restart the laser after moving it.

**RS-232 serial port connector (9-pin, D-Sub)**—provides attachment for a host system to operate the system remotely.

**Controller connector (15-pin, D-Sub)**—provides attachment for the Millennium V control module.

## Millennia V Control Module

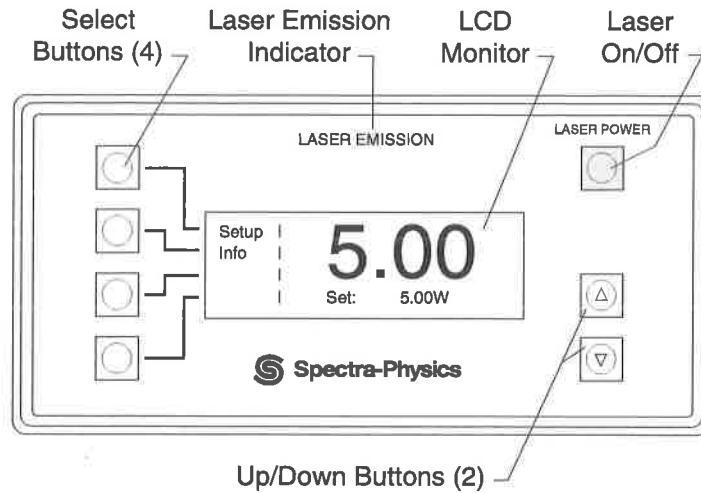

**Figure 4-3: The Millennia V Control Module**

### Controls

There are 7 buttons on the controller that are used to operate the Millennia V laser (Figure 4-3).

**Select buttons (4)**—are located to the left of the LCD screen and are used to select one of the four possible actions that are shown on the left side of the screen. For example, pressing the top left button in Figure 4-3 brings up the Setup menu. When up/down arrows are shown on the screen, press the associated button to scroll the text.

**LASER POWER button**—performs 3 functions: (a) begins the laser warm-up cycle, (b) turns on the laser and (c) turns off the laser. (Note: the power supply must also be on and its LASER DIODE interlock keyswitch set to ON in order for the laser to turn on). Press the button once to begin the warm-up cycle. Then when the cycle completes, press and hold it in to turn on the laser. The LASER EMISSION indicator on the controller panel flashes and the emission indicator on the laser head turns on while the button is held in and emission is imminent (a CDRH delay of about 6 seconds). The indicator stops flashing and stays on when emission occurs.

**Up/down buttons**—in the lower right corner of the panel, when pressed, increase or decrease the value displayed on the screen (such as a power setpoint), or allow the operator to select a parameter from a list that is to be changed or displayed.

### Indicators

**LCD monitor**—provides feedback and control of the laser, depending on which menu is displayed. Large digits always display *actual output power*. Below output power, displayed in smaller text is the output power setpoint (when power mode is selected), or the percentage of maximum current

(when current mode is selected), or “RS-232 Enabled” if the system is being operated remotely via the RS-232 serial link.

**LASER EMISSION indicator**—flashes prior to laser emission, then stays on when laser output is present.

**Connections**

There are no connectors on the control module. The 3 m control cable is permanently attached. Do not try to remove it. The cable plugs into the 15-pin controller connector on the rear panel of the laser head.

**T40 Power Supply**

All controls, indicators and connections on the power supply are made on the front panel. Figure 4-4 shows the front panel.

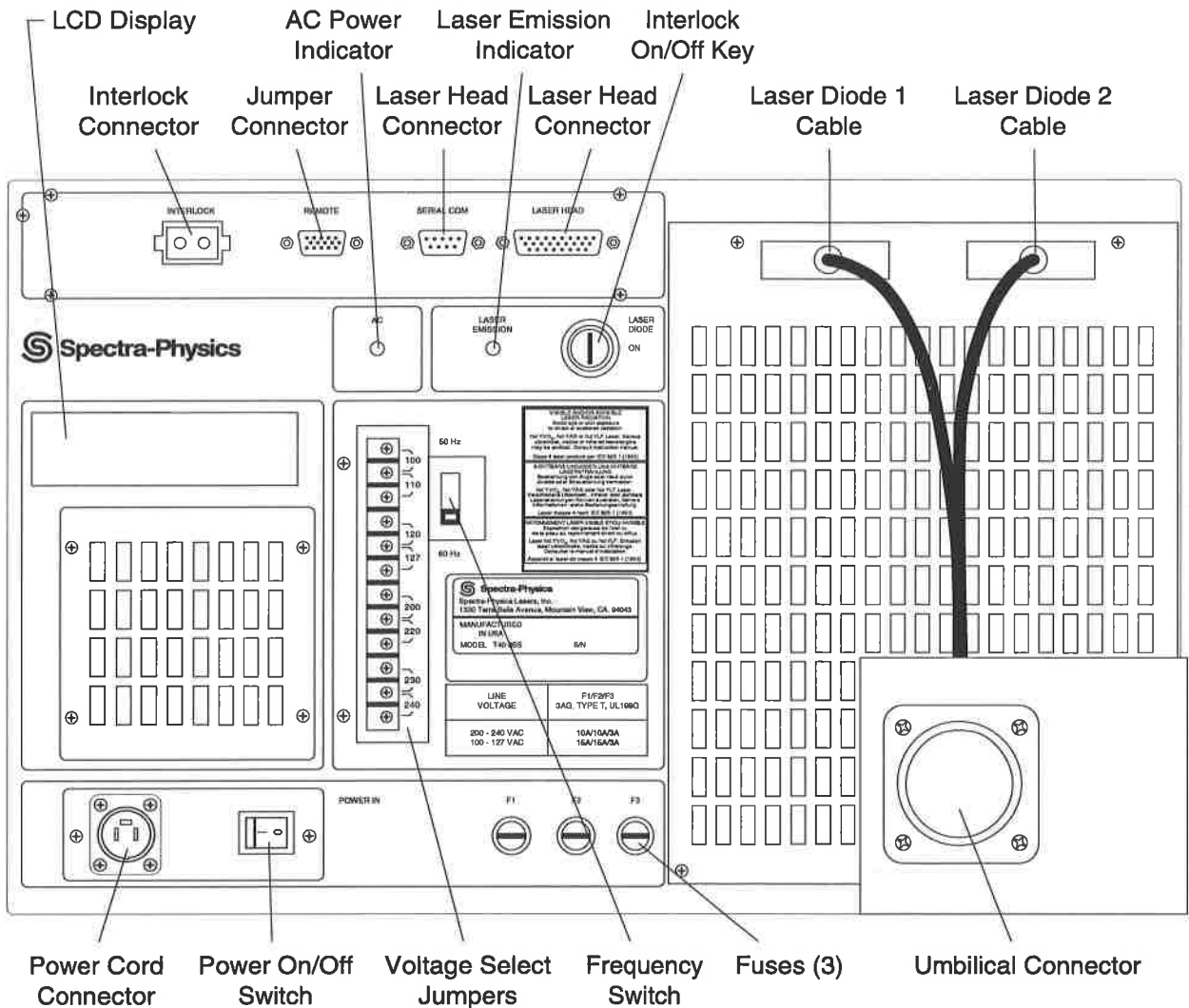

**Figure 4-4: The T40 Power Supply Control Panel**

**Controls**

**Key switch**—provides security to prevent unauthorized use of the laser. When power is applied and the key is inserted and turned to the ON position, the LASER EMISSION indicator lights and emission occurs after about a 6 second delay. Control then transfers to the Millennia V controller or to the host system (via the RS-232 link), depending on configuration.

**Frequency switch**—provides a means to set the system for 50 or 60 Hz operation. Verify this switch is correctly set prior to turning on the system. To set it, slide it to the position that matches the line frequency you are using.

**On/off switch**—provides power to the laser system when set to the on (I) position. When first turned on, the power supply performs an internal diagnostic check and the doubler oven in the laser head is allowed to warm up. From a cold start, this takes about 30 minutes. It is therefore strongly recommended that this switch be left in the “on” position unless the system is not to be used for an extended period of time. For safety, however, turn off the LASER DIODE key and remove it to prevent unauthorized use of the laser.

**Fuses (F<sub>1</sub>, F<sub>2</sub>, F<sub>3</sub>)**—provide a safety valve for various circuits. Replace fuses F<sub>1</sub>, F<sub>2</sub> and F<sub>3</sub> according to the table below for the line voltage used. To access a fuse, use a medium flat blade screwdriver to turn the slotted fuse cap counter-clockwise, then pull the cap off and remove the fuse. Assemble in reverse order.

| Voltage       | Fuse (Type 3AG) F <sub>1</sub> /F <sub>2</sub> /F <sub>3</sub> |
|---------------|--|
| 200 – 240 Vac | 10 A/10 A/3 A  |
| 100 – 127 Vac | 15 A/15 A/3 A  |

**Indicators**

**AC indicator**—turns on immediately when line power is applied to the system and the power switch is turned on.

**LASER EMISSION indicator**—turns on when the LASER DIODE keyswitch is set to the ON position, thus indicating there is laser emission or that it is imminent.

**LCD display**—is a 4-line, 20-character display that shows the progress of the power-up diagnostics and will display error codes for any power supply failure(s). These codes are used by Spectra-Physics service technicians to diagnose problems in the power supply; they are not for use by the user.

## Connections

**INTERLOCK connector (2-pin)**—provides attachment for a safety switch. These contacts must be shorted together before the laser will operate. A defeating jumper plug is installed at the factory to permit operation without a safety switch. The plug can be replaced with a similar non-shortening plug that is wired to auxiliary safety equipment (such as a door switch) to shut off the laser when actuated (opened). Such a switch must have a minimum rating of 100 mA at 12 V.

**REMOTE connector (15-pin)**—provides attachment for a jumpered plug that configures the T40 power supply for use with the Millennia V laser. *Do not remove the plug: doing so will keep the system from starting, or will shut it off if it is already on.* Do not confuse this connector with the 15-pin connector on the laser head.

**SERIAL COM connector (9-pin)**—provides attachment for control lines from the umbilical. Do not disconnect the umbilical connector attached to it. Also, do not confuse it with the serial connector on the laser head which provides attachment for a terminal or computer.

**LASER HEAD connector (27-pin)**—provides attachment for control lines from the umbilical. Do not disconnect the umbilical connector.

**Laser diode cable connectors (2)**—provides attachment for the armored fiber-optic cables. These cables are permanently attached to the diode modules. Do not try to disconnect them. Call Spectra-Physics to have a service engineer replace the diodes when needed.

**Power cord connector**—provides attachment for the twist-on power cord provided with the unit. Connect the cord to a power source capable of providing 15/10 A at 110/220 V.

**Voltage select jumper terminal block**—provides a means for matching the system to the local power line. Use a screwdriver to loosen the screws, then position the jumpers according to the silkscreen for the voltage desired. After making any adjustments, verify the screws are tight.





With the exception of the vertical and horizontal controls of mirror  $M_6$ , there are no internal controls to adjust or optics to change. This makes the Millennium V laser very easy to set up and operate. The following instructions will get you operational in a very short time.

When you received your laser, it was packed with the laser head and power supply already connected. Do not disconnect the umbilical cables from either end!

## Laser Installation

### Note



---

The following installation procedure is not intended as a guide to the initial installation and set-up of your laser. Please call your Spectra-Physics service representative to arrange an installation appointment, *which is part of your purchase agreement*. Allow only personnel qualified and authorized by Spectra-Physics to install and set up your laser. Spectra-Physics provides training in the use of this laser. Please contact your Spectra-Physics Lasers representative if you desire training. You will be charged for repair of any damage incurred if you attempt to install the laser yourself, and such action might also void your warranty

---

All the tools and equipment you need to set up the Millennium V laser are in your accessory kit.

### Installing the Laser Head

1. Remove the laser head, power supply and control module from the shipping crate and inspect for damage. Refer to the “Unpacking and Inspection” notes at the front of this manual.
2. Move the laser system into place.

### Warning!



---

Be careful when moving your system that any bend in the umbilical does not exceed the 10 cm (4 in.) minimum radius. Exceeding this limit can fracture and/or break the fiber bundles. Also, be careful not to snag any of the various cables extending from the power supply.

---

To move the laser, set the power supply on the ground and the laser head and controller on top of it, then roll the laser to the table. The laser head is much lighter than an ion laser of similar size (approximately 14 kg), and it can be picked up by one person.

3. Set the laser head on a suitable optical table and align it to the target system.
4. For now, roll the power supply under the table or out of the way. The umbilical and power cable are each about 3 m long.
5. Remove the laser head cover.

Two screws hold the cover on. Use one of the large-handled Allen drivers from the accessory kit to turn the screws  $\frac{1}{4}$  turn counterclockwise, then lift the cover off.

6. Adjust the height of the laser head.
  - a. Loosen the large locking nut on each leg. The nuts are threaded onto each leg and jam against the bottom of the base plate to lock the foot in place and to add stiffness to the foot.
  - b. From inside the laser head, use a  $\frac{5}{32}$  in. Allen driver to adjust each leg by screwing it up and down.
  - c. When the height is correct, tighten the locking nuts up against the base plate again.
7. Secure the laser head to the table with the four foot clamps provided.
8. Replace the cover on the laser.

This completes the laser head installation procedure.

### Installing the Control Module

Controller installation consists of setting the unit in a convenient place on the table and plugging the control cord into the 15-pin controller connector on the laser head rear panel (Figure 5-1).

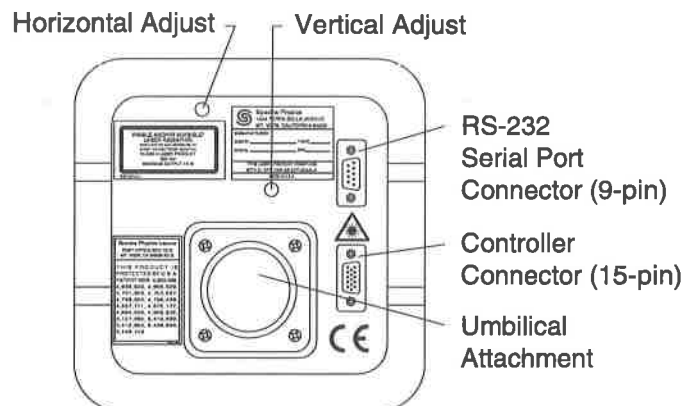

Figure 5-1: The Millennium V Laser Head Rear Panel

If a remote host system is to be used to control the Millennia V laser, refer to the end of Chapter 6, "Operation: The RS-232 Serial Port," for information on wiring and connections, baud rate, command language, etc.

### **Installing the Power Supply**

1. Place the power supply in a convenient location within 3 m of the laser head (the length of the umbilical cable).
2. Verify the cable connections from the umbilical are still tight.  
The REMOTE, SERIAL COM and LASER HEAD connectors should never be disconnected from the power supply panel. If, for some reason, they do get disconnected, take care to reconnect them. Each plug has a different number of pins so they cannot be swapped. Tighten the retaining screws when you are done.
3. Verify the interlock jumper is in place or, if desired, remove it and add a non-jumpered connector and wire it to a safety switch. The switch must be wired so that when the device is actuated (e.g., a door is opened), the switch opens and the laser turns off.
4. Verify the voltage selection jumpers are correctly set to match the voltage in your area.

To change the setting, simply loosen the screws and move the jumpers to the proper setting. Refer to the silk-screened voltage notation next to the terminal strip. If the voltage is changed, fuses  $F_1$  and  $F_2$  must also be changed. Refer to the fuse rating requirements for the voltage setting used in the specifications table in Chapter 3.

5. Verify the frequency switch is set to the line frequency in your area.
6. Attach the power cord to the power supply, then to the power source.

This completes the installation of the power supply and the Millennia V system.

### **Installing the Chiller**

Refer to the User's Manual that came with your chiller for detailed information on installing and starting the chiller.

1. Place the chiller on the floor close enough to the power supply so the chiller hoses can reach from the chiller connectors on the back of the unit to the umbilical bracket near the power supply.

**Warning!**



Do not place the chiller above the laser. If the unit is installed incorrectly and develops a leak, dripping water may damage the laser.

2. Screw both hoses onto the chiller and tighten.

The hose connections are not polarized. Finger tight is enough: do not overtighten.

3. Verify there is water in the chiller, then turn on the chiller and verify water is flowing.
4. Inspect for leaks at the hose connections and also inside the laser head where the polyurethane hoses attach to the Z-head.
5. Set the chiller temperature for 18°C (64°F).
6. Turn off the chiller.

This completes the installation of the Millennia V system.

## Alignment

No formal alignment procedure is required for the Millennia V laser system: there are no knobs to adjust or no optics to change at this point. If you are ready to turn on the laser, refer to Chapter 6, "Operation," for instructions.

Please read this entire chapter and Chapter 2 on laser safety before using your laser for the first time.

Once the Millennia V has been installed and the output optimized using this procedure, we strongly suggest you leave the power switch on the power supply (located in the lower left corner of the panel) in the on position at all times. This will drastically reduce warm-up time by keeping the SHG doubling crystal oven on, and will help protect the crystal, especially in humid environments.

## Using the Control Module

The controller is a convenient device for operating the Millennia V laser (refer to Figure 6-1).

Use the four buttons on the left side of the panel to select one of the four possible options shown on the left side of the screen. For example, press the top left button to go to the Setup menu or the next button down to go to the Info menu, etc. As is the case here, not all menus use all the buttons.

The LASER POWER button turns the laser on and off.

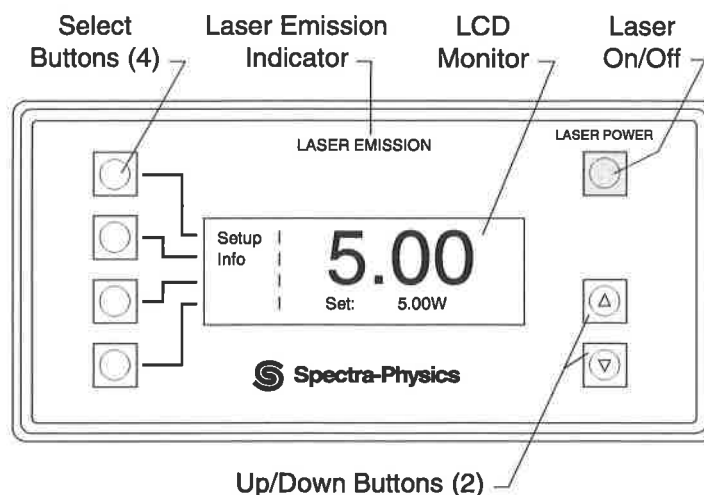

**Figure 6-1: The Millennia V Controller Showing the Default Main Menu.**

The up/down buttons in the lower right corner either increase or decrease the value displayed on the screen (such as the power setpoint), or allow you to select or change a parameter from a list on the display.

The LCD screen displays several things, but what is displayed depends on the menu in use. The large digits always display *actual output power*, and below that, in smaller text, is either the output power setpoint (when power mode is selected) or the percentage of maximum current (when current mode is selected). RS-232 ENABLED is shown if the system is being operated remotely via the serial link.

In general, use:

- the Main menu to monitor output power and to set the power or current setpoint (the desired output).
- the Setup menu to select power or current mode, to activate or deactivate standby mode and to set its delay time before activation, to set Main menu power setpoints P1 and P2 and to select local or RS-232 control of the system. RS-232 commands are listed at the end of this chapter.
- the Info menu to view the diode drive current, the temperature for each laser diode, the temperature status of the SHG doubling crystal, and the revision level of the Millennia V software. Also included is a history (HST) line that shows the last three system error codes.

Refer to the following sections for more information on each menu.

### The Menu System

Four menus, Main, Setup, Standby, and Information, are used to control and monitor the Millennia V. Sample menu displays are shown in Figure 6-2.

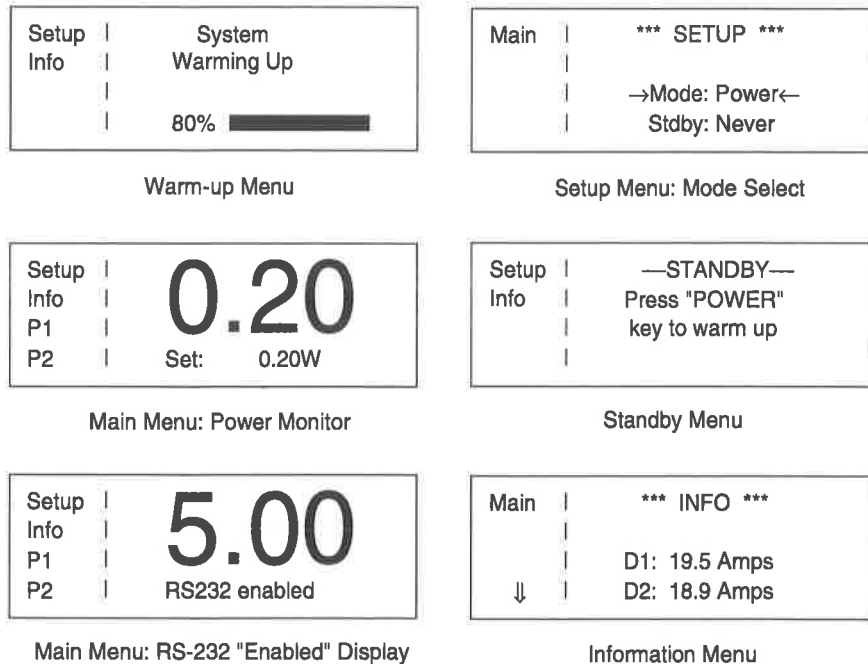

Figure 6-2: The Millennia V Menus

The upper left-hand frame shows the warm-up menu that is displayed soon after the system is powered up from a cold start (the power supply was turned off). It allows you to monitor the warm-up process, which takes about 30 minutes. If you are controlling the system remotely using the serial interface, a query command allows you this same monitoring capability (refer to the “Queries” section later in this chapter).

The Standby menu is displayed anytime the power supply is left on but there has been no laser emission for a time greater than the Stdbby delay time setting.

The following sections describe the four menus.

## The Main Menu

When the system is ready for operation following the warm-up sequence, the Main menu is displayed. From here you can set the output power and monitor system performance. The large numbers indicate actual output power; the smaller numbers below it indicate either the desired output power (the power setpoint when the system is set for power mode), the desired laser diode drive current (the current setpoint, as a percentage of maximum current, when the system is set for current mode), or RS-232 ENABLED when the system is operated remotely via the serial link. The left figure below shows the power mode display; current mode is shown on the right. When the system is tracking correctly in power mode, the two numbers, actual output power and setpoint, are the same,  $\pm 0.01$  W.



To change the power or current setpoint, either press one of the preset power setpoint keys, P1 or P2, to move directly to a preset power (set in the Setup menu), or use the up/down buttons to set a new value. Note that when the buttons are held down, the setpoint numerical update pauses from time to time. This is normal. To change from power to current mode, or vice versa, use the Setup menu.

If an error occurs, ERROR flashes in the lower left corner of the Main menu. Press the lower left button to display the error source. (Error codes and their definitions are listed in Appendix A.) When the problem is corrected, the ERROR message turns off. If the error code is generated by the power supply, it is logged on the history (HST) line in the Info menu.

Menus available from the Main menu are:

- Setup
- Info

## The Setup Menu

Use the Setup menu to change between power and current mode, to activate or deactivate Standby mode and to set its time delay before activation, to set Main menu preset power values for P1 and P2, or to select LOCAL control (using the Millennia controller) or a remote control source (via the RS-232 link). Access this menu from the Main menu.

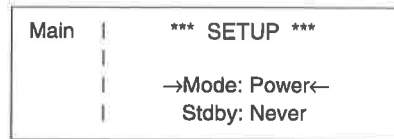

Use the two lower left buttons to scroll the menu up and down; the “selected” item is the one between the horizontal arrows (“Mode: Power” in the example screen above). The value for the “selected” item is changed by using the up/down buttons to the right of the screen. The selections and/or changes are activated upon return to the Main menu. Selections include:

- Mode: Power, Current, RS-232
- Stdby: Never, 4 hours, 2 hours, 1 hour, 30 min, 15 min
- P1 Set: any value between 0.2 and 5.0 W
- P2 Set: any value between 0.2 and 5.0 W

Power mode is used to maintain constant output power and is the “normal” setting. Current mode is used to maintain constant diode current while measuring laser output power. Current mode is primarily used for diode diagnostic purposes.

Standby (Stdby) mode, when active, causes an automatic system power down mode whenever the power supply is left on but there has been no laser emission for a time greater than the Stdby delay time setting. This is the preferred “off” mode when the laser is used on a day-to-day basis. This mode can be defeated, however, by setting the delay time to “Never.”

P1 SET and P2 SET allow you to preset two power levels that can be selected from the Main menu during operation by simply pressing one of the two lower left buttons on that screen. See the Main menu.

When RS-232 is selected, “RS-232” is displayed on the Main menu as shown below, and control is transferred to the host system. The baud rate can be changed to match the speed of the host system. This setting, along with the software commands for serial control, are explained later in this chapter under “The RS-232 Serial Port.” The default RS-232 settings are: 9600 baud, 8 data bits, no parity, 1 stop bit.



Pressing the Main button from the Setup menu returns you to the Main menu.



## The Standby Menu

When “Stdby” is activated in the Setup menu, the Standby menu is automatically displayed whenever the T40 power supply is left on but there has been no emission for more than the delay time set for Stdby (see the Setup menu). This is the recommended, over-night “off” position. Refer to “Turning on the Laser, Warm Start” later in this chapter.

This display is not shown when the system is started cold, i.e., when the power supply has been turned off. Nor can it be accessed from any other menu.

|       |  |                |
|-------|--|----------------|
| Setup |  | —STANDBY—      |
| Info  |  | Press "POWER"  |
|       |  | key to warm up |

## The Information Menu

The Info menu provides diagnostic information on the laser diodes and the SHG doubling crystal. It also contains a history (HST) line that displays the three most recent system error codes for diagnostic purposes. The codes and their definitions are listed in Appendix A. Note that only the power supply codes, 0 through 126, are displayed. The Info menu is accessed from the Main menu.

|      |  |               |
|------|--|---------------|
| Main |  | *** INFO ***  |
|      |  | D1 :19.5 Amps |
| ↓    |  | D2 :18.9 Amps |

Use the select buttons (not the up/down buttons) to scroll the screen (note the down arrow in the picture above). Two lines are displayed at a time as follows, from top to bottom:

- The drive current for each laser diode, D<sub>1</sub> and D<sub>2</sub>.  
Note that it is normal to require greater than 60% of full current before achieving the threshold condition for green output power.
- The temperature of each laser diode.
- The status of the SHG doubling crystal temperature (it is STABLE when the proper temperature is reached).
- The error code history (HST) line.
- The revision level of the Millennia V software. Have this revision number available whenever calling for service.

Pressing the Main button returns you to the Main menu.

## System Start-up/Shut Down

There are two turn on sequences, one for a cold start when the T40 power supply was turned off, and one for a warm start when the system is in Standby mode (when the laser is off but the power supply was left on). Each sequence is described below.

### **Turning On the Laser, Cold Start**

1. Verify that all connectors are plugged into the power supply (they should never be disconnected—if they were, refer to Chapter 5, “Installation and Alignment,” for instructions on re-connecting them).
2. Turn on the power supply power switch.
3. Turn on the chiller. Verify it is set to 18°C.  
Refer to the chiller user’s manual for instructions.
4. Turn on the power supply key switch.

### **Power Supply Start-up**

As the system starts up, the following message sequence is displayed on the power supply LCD screen:

- “Spectra-Physics” followed by the software version number.
- “System Initializing”
- “Bypass delay time”
- “Laser Diodes Off”
- “Status – Wait”
- “Cooling System Test”
- “Diode Safety Check”

If the key switch is not set to ON, the system will not start up and the following is displayed on the panel: “System Error, Open Interlock.” Simply set the switch to ON to clear the error message and enable the system.

- “Adjusting Temperature”

This message remains on screen until the laser diodes are at operating temperature. At this time, the Warm-up menu is displayed on the controller.

- “Boot Complete, Laser Diodes Off, Power Mode Ready”

This is the final display from the power supply, which indicates it is ready for use.

### Controller Start-up

The following message sequence is displayed on the controller as the system turns on:

- “Spectra-Physics”
- “Welcome to the new Millennia V”

After the welcome message, the system begins the warm-up cycle, which can take up to 30 minutes. A time bar is displayed (0 to 100%) to indicate progress:

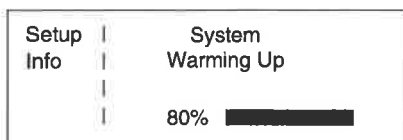

5. When the system has warmed up, the following screen is displayed:

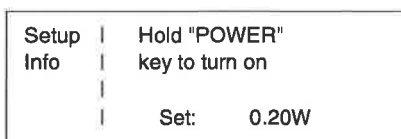

Press and hold in the LASER POWER button until the laser starts. When the button is pressed, the LASER EMISSION light flashes for a few seconds. Then, when laser emission occurs, it stops flashing and remains on, and the emission indicator on the laser head turns on to indicate radiation is present.

At this point, the Main menu is displayed and, for safety, output power ramps up slowly to 0.20 W. 0.20 W is displayed if the laser was set to power mode when it was last used, or an equivalent current value is displayed if the laser was set to current mode. Power mode is shown in the Main menu below.



6. Use the Setup menu to change the laser mode, if desired.
7. From the Main menu, set laser output power using the up/down buttons. Actual output power will follow the setpoint value.

This completes the cold start turn-on sequence. The system is now ready for use.

### Turning On the Laser, Warm Start

This procedure assumes the unit was left in Standby mode after it was last used, i.e., the laser was turned off, but the power supply was left on. When this is the case, the following Standby prompt is displayed.



1. Press the LASER POWER button to begin the short warm-up cycle. The following prompt is displayed for about 2 minutes while the diode temperature stabilizes:



2. When the system has warmed up, the following screen is displayed:

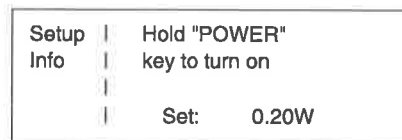

Press and hold in the LASER POWER button until the laser starts. When the button is pressed, the LASER EMISSION light flashes for a few seconds. Then, when laser emission occurs, it stops flashing and remains on, and the emission indicator on the laser head turns on to indicate radiation is present.

At this point, the Main menu is displayed and, for safety, output power ramps up slowly to 0.20 W. 0.20 W is displayed if the laser was set to power mode when it was last used, or an equivalent current value is displayed if the laser was set to current mode. Power mode is shown in the Main menu below.



3. Use the Setup menu to change the laser mode, if desired.
4. From the Main menu, set laser output power using the up/down buttons. Actual output power will follow the setpoint value.

This completes the warm start turn-on sequence. The system is now ready for use.

**Note**

When Standby mode is activated, the system automatically reverts to a power down mode after the preset delay time and the Standby menu is displayed. To restart the unit, follow the procedure for a warm start turn-on.

### Optimizing Laser Output

**Caution!**

Perform the following adjustment while in current mode. You will not be able to see any change in power while in power mode: the system will compensate for any changes you make. Also, there must be some output power present before you begin. If this is not the case, call your Spectra-Physics representative.

Use the two large-handled Allen drivers provided in the accessory kit to adjust the horizontal and vertical controls of the M<sub>6</sub> HR. These controls are accessed through holes in the laser rear panel as shown in Figure 6-3.

Horizontal Adjust      Vertical Adjust

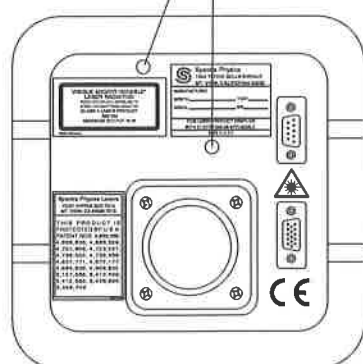

**Figure 6-3: Millennium V Rear Panel**

1. From the Setup menu, set the system in current mode.
2. From the Main menu, set the laser for the desired output power.
3. While monitoring output power on the controller, adjust the horizontal control back and forth until output power is as high as possible.
4. Similarly, adjust the vertical control.
5. Repeat these adjustments, first turning one control, then the other, back and forth, until maximum power is reached.
6. Return the system to power mode.

Do not make any other adjustments to the laser head (see warning).

Warning!



---

*DO NOT* make any other adjustments to the laser head, or a full factory realignment of the head might be required. Such a realignment is not part of your warranty and you will be charged accordingly.

---

This completes the output optimization procedure.

### Turning Off the Laser

Note



---

Once Millennia V output is optimized, we suggest you leave the unit in Standby mode when not in use, i.e., turn the laser off, but leave the power supply power switch in the “on” position at all times. This reduces warm-up time and keeps the SHG crystal at optimum operating temperature.

---

To turn off the laser, simply:

1. Press the LASER POWER button to turn off the laser.
2. Turn the *key switch* on the power supply to OFF and remove the key to prevent unauthorized use. Leave the power switch on the power supply in the “on” position.

If Standby mode has been activated, the system will go to Standby mode automatically after the preset delay time. This is the preferred “off” mode for day-to-day operation. If you are not going to use the laser for an extended period of time, turn off the power supply completely.

3. Turn off the chiller.

This completes the turn off sequence.

## Setting the SHG Crystal Temperature

We strongly recommend you do not change the temperature of the SHG doubling crystal. There are, however, a very few instances where this might be appropriate and the following information is provided for use in those rare cases.

To change the SHG crystal temperature:

1. Select the Setup menu.
2. Place the system in current mode and set it for the desired output power.
3. Press the 2 lower left selection buttons at the same time.

The following is displayed:

|       |  |               |
|-------|--|---------------|
| Main  |  | ** SHG Adj ** |
| RESET |  |               |
|       |  | →SHG Adj. 35← |
|       |  |               |

4. Use the up/down keys to change the temperature count.  
Temperature is given as  $\pm 127$  counts from a nominal setting. The system is shipped from the factory at a calibrated setting somewhere between 0 and  $\pm 25$  counts. If you get into trouble, press the RESET button to return the SHG doubling crystal to this factory temperature setting.
5. Press the MAIN button to leave the crystal adjust mode and return to the Main menu.

This completes the SHG crystal temperature-set procedure.

## The RS-232 Serial Port

### Pinout/Wiring

The Millennia V serial port accepts a standard 9-pin D-sub male/female extension cable for hook-up. Only three of the pins are actually used:

| Pin Numbers | Usage                           |
|-------------|---------------------------------|
| 2           | transmit data (Millennia V out) |
| 3           | receive data (Millennia V in)   |
| 5           | signal ground                   |

### Communications Parameters

Communications must be set to 8 data bits, no parity, one stop bit, using the XON/XOFF protocol (do not use the hardware RTS/CTS setting in your communications software). The baud rate is variable and can be set to 1200, 2400, 4800 or 9600 (default). The rate is determined at system power-up by reading positions 1 and 2 of switch S<sub>1</sub> on the laser head pc board. Figure 6-4 shows the location of the DIP switch on the pc board, and the table below describes the function of the switches.

#### Switch S<sub>1</sub>

| Position 1 | Position 2 | Baud Rate      |
|------------|------------|----------------|
| off        | off        | 1200           |
| off        | on         | 2400           |
| on         | off        | 4800           |
| on         | on         | 9600 (default) |

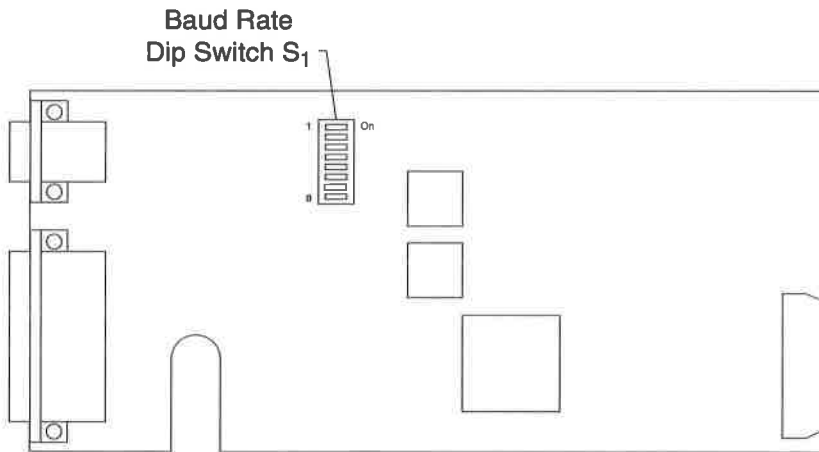

**Figure 6-4: Laser head pc board showing the location of baud rate dip switch S<sub>1</sub>.**



## Command/Query/Response Format

All commands and responses are in ASCII format. Commands to the Millennium V system are terminated by an ASCII carriage return, line feed, or both. All responses from the Millennium V are terminated by an ASCII line feed character. In the examples below, a carriage return is indicated by <CR>, and a line feed by <LF>.

### Commands

#### ON – Turn On Laser

*ON*<CR>

The response to this command depends on whether or not the system is warmed up. Use the *?WARMUP%* query (see “Queries”) to determine the progress of the warm-up cycle (see table below).

A response of “0” means the system is in Standby mode. If this is the case, issue an *ON* command to begin the temperature stabilization cycle. When the response to the *?WARMUP%* query reaches “100%”, the laser can be started. Do not issue an *ON* command while the response to *?WARMUP%* is “1 to 99”.

| If the response to <i>?WARMUP%</i> is... | The response to <i>ON</i> is...   |
|--|---|
| 0  | to begin diode temperature stabilization.<br>(approximately 2 minutes)                        |
| 1 to 99                                  | an execution error.<br>(The EXE_ERR bit in the status byte is set.)                           |
| 100                                      | the laser diodes turn on, and the system output ramps to the most recently set power/current. |

Note: when the laser turns on, it will be in the mode (power/current) that was in effect when the unit was turned off.

#### OFF – Turn Off Laser

*OFF*<CR>

Turns off the laser diodes and diode temperature regulation (the latter reduces electrical power consumption), but the SHG crystal oven temperature is maintained for quick warm-up time. Latched interlocks are cleared. Thirty minutes after the laser diodes have been turned off, the system enters the Standby mode.

**P:x.x – Set Power**

Sets laser output power to the nearest tenth watt if the unit has been previously set to power mode using the “M” command. This command is ignored when the system is in current mode. The minimum setting is 0.2 watts, the maximum is 5.5 watts. Commands outside this range are ignored.

- P:5<CR>*            Sets the output power to 5.0 W.
- P:5.0<CR>*        Sets the output power to 5.0 W (no change).
- P:4.9<CR>*        Sets the output power to 4.9 W.

**C%:xx – Set Percent Current**

Sets the laser current to a percentage of maximum current if the unit has been previously set to current mode using the “M” command. This command is ignored when the system is in power mode or when settings less than zero or greater than one hundred percent are requested.

- C%:50<CR>*        Sets both diodes to 50% current.

**Mx – Set Mode**

Sets the laser mode so that output is current regulated or power regulated. The diode current or output power is ramped to the previous set value.

- M1<CR>*            Sets the laser to power mode.
- M0<CR>*            Sets the laser to current mode.

**Queries**

**?P – Get Power Status**

- ?P<CR>*            Requests the value of the laser output power in watts. The response looks like “4.90 W<LF>”.

**?Cx – Get Diode Operating Current Status**

- ?C1<CR>*            Requests the value of the drive current for diode 1. Diode 1 = C1, diode 2 = C2. A typical response is “25.36A1<LF>,” which is interpreted as 25.36 amps for diode 1.

**?M – Get Mode Status**

- ?M<CR>*            Requests system mode status. The system responds with “1<LF>” for power mode, or “0<LF>” for current mode.

**?SHGS – Get SHG Oven Status**

- ?SHGS<CR>*        Requests the status of the SHG oven. The system responds “0S<LF>” if the temperature is settled, “1S<LF>” if the oven is heating, and “2S<LF>” if it

is cooling. Values less than zero indicate an error (such as a broken wire or loose cable).

#### ?IDN – Get Identification String

*?IDN<CR>* Requests a system identification string. The system returns an ASCII string that consists of four fields: manufacturer, product, software revision number, and serial number (“Ø” if the latter is not implemented). A typical return would be “Spectra-Physics, Millennia, 1.02, 0<LF>.”

#### ?STB – Get Status Byte

This query requests a system status byte that indicates which command errors (if any) have occurred and whether the laser is on or off. The integer value returned represents the sum of the value of the bits in the status byte. The bit positions are defined by Table 6-1 below. Each time a status byte is requested, its register is cleared so that a new status byte can be generated.

The status register accumulates the most recent commands and tracks their validity. Consider the following sequence of commands:

|                       |  |
|-----------------------|--|
| <i>P:10&lt;CR&gt;</i> | Since the requested power is out of range, the EXE_ERR bit is set. |
| <i>P:5&lt;CR&gt;</i>  | Valid command, sets power to 5 watts.                              |
| <i>M1&lt;CR&gt;</i>   | Valid command, sets unit to power mode.                            |
| <i>ON&lt;CR&gt;</i>   | Valid command, turns on the laser diodes.                          |
| <i>?STB&lt;CR&gt;</i> | Reads and clears the status byte.                                  |

The status byte returned would be “194<LF>” since the ANY\_ERR, LASER\_ON, and EXE\_ERR bits are set (194=2+64+128). Table 6-1 describes all the possible errors; Table 6-2 lists all the possible combinations.

**Table 6-1: Query Errors**

| Binary Digit | Decimal Value | Name          | Interpretation   |
|--------------|---------------|---------------|--|
| 0            | 1             | CMD_ERR (CE)  | Command error.<br>Something was wrong with the command format, the command was not understood  |
| 1            | 2             | EXE_ERR (EE)  | Execution Error<br>A command was properly formatted, but could not be executed. For example, a power command of "P:0<CR>" was sent, when the minimum allowed power is 0.2 watts. |
| 2            | 4             | (reserved)    |  |
| 3            | 8             | (reserved)    |  |
| 4            | 16            | (reserved)    |  |
| 5            | 32            | SYS_ERR (SE)  | Any "system" error. (An open interlock, or an internal diagnostic)   |
| 6            | 64            | LASER_ON (LO) | Indicates that laser emission is possible.   |
| 7            | 128           | ANY_ERR (AE)  | Any of the error bits are set.   |

**Table 6-2: Error Return List**

| Binary DigitS | Decimal Value | Errors Returned        |
|---------------|---------------|------------------------|
| 0100 0000     | 64            | LO                     |
| 1000 0001     | 129           | CE + AE                |
| 1000 0010     | 130           | EE + AE                |
| 1000 0011     | 131           | CE + EE + AE           |
| 1010 0000     | 160           | SE + AE                |
| 1010 0001     | 161           | CE + SE + AE           |
| 1010 0010     | 162           | EE + SE + AE           |
| 1010 0011     | 163           | CE + SE + EE + AE      |
| 1100 0001     | 193           | CE + LO + AE           |
| 1100 0010     | 194           | EE + LO + AE           |
| 1100 0011     | 195           | CE + EE + LO + AE      |
| 1110 0000     | 224           | SE + LO + AE           |
| 1110 0001     | 225           | CE + SE + LO + AE      |
| 1110 0010     | 226           | EE + SE + LO + AE      |
| 1110 0011     | 227           | CE + EE + SE + LO + AE |

**?WARMUP% – Get Warm-up Status**

*?WARMUP%<CR>* Reads the status of the system warm-up time as a percent of the predicted total time (see the table below). The system responds with a value similar to “050%<LF>”. When the response is “100%<LF>”, the laser can be turned on.

Note: an error condition, such as an open interlock, may not affect the *?WARMUP%* command. To check for other errors, request the status byte with the *?STB* query command.

| System Status                                   | ?WARMUP%           |
|---|--------------------|
| Initial AC power-on warm-up                     | Between 1% and 99% |
| System is ready to turn on the laser diodes     | 100%               |
| System is in Standby mode                       | 0%                 |
| System is warming up after leaving Standby mode | between 1% and 99% |

**?HDREV – Get Head Software Revision**

*?HDREV<CR>* Returns a Millennia V laser head software revision number similar to “2.01<LF>”.

**?PSREV – Power supply Software Revision Query**

*?PSREV<CR>* Returns a T40 power supply software revision number similar to “4420 REV D<LF>”.

**?RMREV – Controller Software Revision Query**

*?RMREV<CR>* Returns the controller software revision number. A typical response is “1.10<LF>”.

**?EC – System Error Code Query**

*?EC<CR>* Returns the current error code. The code returned is the same as that displayed on the controller, if it is attached. Refer to the error code listing in appendix A for explanations.

**?H – History Buffer Query**

*?H<CR>* Returns a 16-byte (16 code) error list from the “history buffer” with the most recent error listed first. The history buffer only stores error codes generated by the power supply, numbers 0 – 126. Errors from the Millennia V laser head are not recorded and, therefore, will not be returned.

**?C%SET – Last Current Command Query**

**?C%SET<CR>** Returns the value for the last percentage current commanded (“C%”), not the actual diode current. A typical response might be “75.1%<LF>”.

**?PSET – Last Power Command Query**

**?PSET<CR>** Returns the value for the last power command (“P%”), not the actual laser output power. A typical response might be “0.20W<LF>”.

**?C%<CR> – Actual Current Setting Query**

**?C%<CR>** Returns a value equal to the actual operating percentage of maximum diode current. A typical response might be “75.1%<LF>”.

This completes the operation section.

### Preventive Maintenance

The Millennia V has been designed for “hands-off” operation, requiring minimal maintenance.

Its top cover protects the internal components from outside contamination and prevents unwanted stray optical radiation from escaping the system.

The Millennia V should always be operated with the top cover in place.

Dust tubes are used to enclose the entire cavity beam to minimize the amount of maintenance required. These, too, should always be left in place.

Although removal of the fiber optic bundles is not recommended or needed, always inspect, clean, and re-inspect the fiber ends whenever they are removed from the Z-head.

It is recommended to annually check the safety features of the Millennia V to ensure safety is maintained (see Chapter 2, “Laser Safety” for details).

### Equipment Required

- Dry nitrogen, canned air, or rubber squeeze bulb
- Photographic lens tissue
- Clean forceps or hemostats (optional but very helpful)
- Powder-free finger cots or gloves for handling optical components
- Fiber holding fixture for cleaning and inspection of fiber bundle (optional but very helpful)
- Spectroscopic-grade methanol (methyl alcohol) or propanol (2-propanol or isopropyl alcohol). Acetone may be used on intracavity optics only; do not use it on the fiber bundles.
- Clean dropper or droplet dispensing unit for the alcohol
- Inspection microscope, 50 x to 100 x typical

### Cleaning Laser Optics and Optical Fibers

All parts that normally come in contact with laboratory or industrial environments retain surface contamination that can be transferred to optical components during handling, cleaning and assembly. Indeed, skin oils can be very damaging to optical surfaces and coatings and can lead to serious degradation problems under intense laser illumination. It is therefore essential that only clean items come into contact with optical components and the mechanical parts immediately surrounding them.

When cleaning optics, be very careful not to scratch the optic surface. Laser optics are made by vacuum-deposited microthin layers of materials of varying indices of refraction on glass substrates. If the surface is scratched to a depth as shallow as 0.01mm, the operating efficiency of the optical coating will be reduced significantly.

Losses due to unclean optics or fiber ends, which might be negligible in ordinary optical systems, can disable a laser and severely reduce the effectiveness of a frequency doubler. Dust on intracavity mirror surfaces can reduce output power or cause total failure. Cleanliness is essential! However, as long as the Millennia V intracavity optics are kept enclosed (i.e., the dust tubes are never taken off) and the fiber optics are not removed from the Z-head, there is little need for the routine maintenance associated with ion lasers. However, if cleaning is required, the maintenance techniques described below must be applied with extreme care and with attention to detail.

Remember, "clean" is a relative description; nothing is ever perfectly clean, and no cleaning operation ever completely removes contaminants. Cleaning is a process of reducing objectionable materials to acceptable levels.

**Warning!**



---

*Never clean the crystals with solvents*, especially the SHG doubling crystal. Only use puffs of air to remove dust. If the crystals become contaminated, consult the factory.

---

**Warning!**



---

**NEVER** remove any of the optics in the Millennia V laser. They are enclosed to minimize contamination and are designed to be cleaned in-place when and if required. Removing them will require a major realignment that can only be performed at the factory. Such an alignment is not covered by your warranty.

---

**Caution!**



---

Always wear clean, lint-free finger cots or gloves when handling optics and intracavity parts. Remember not to touch any contaminating surface while wearing gloves; you can transfer oils and acids onto the optics.

---

- Work in a clean environment and, whenever possible, over an area covered by a soft, lint-free cloth or pad.
- Wash your hands thoroughly with liquid detergent, then put on finger cots before touching any optic.  
Body oils and contaminants can render otherwise fastidious cleaning practices useless.
- Use filtered dry nitrogen, canned air, or a rubber squeeze bulb to blow dust or lint from the optic surface before cleaning it with solvent. Permanent damage can occur if dust scratches the glass or mirror coating.



- Use spectroscopic, electronic, or reagent grade solvents. Don't try to remove contamination with a cleaning solvent that may leave other impurities behind.  
Since cleaning simply dilutes contamination to the limit set by solvent impurities, solvents must be as pure as possible. Use as little solvent as possible: as any solvent evaporates, it leaves impurities behind in proportion to its volume. Avoid rewiping a surface with the same swab: a used swab and solvents will redistribute contamination, they will not remove it.
- Store methanol and acetone in small glass bottles.  
These solvents collect moisture during prolonged exposure to air. Avoid storage in bottles where a large volume of air is trapped above the solvent.
- Use Kodak Lens Cleaning Paper™ (or equivalent photographic cleaning tissue) to clean optics.
- Use each piece of tissue only once: dirty tissue merely redistributes contamination—it does not remove it.

**Warning!**

Do not use lens tissue designated for cleaning eye glasses. Such tissue contains silicones. These molecules bind themselves to the optic coatings and can cause permanent damage. Also, do not use cotton swabs, e.g., Q-Tips™. Solvents dissolve the glue used to fasten the cotton to the stick, resulting in contaminated coatings. Only use photographic lens tissue to clean optical components.

Tools and mechanical items used with optical systems should be thoroughly degreased and cleaned (preferably in an ultrasonic bath) and rinsed in clean solvents (acetone or alcohol) and/or deionized water prior to use. If used repeatedly over time, these items should be re-cleaned at regular intervals. If you have any questions regarding these procedures, please contact your Spectra-Physics service representative.

## General Procedure for Cleaning Optics

*All optics are to be cleaned in place.*

**Warning!**



*NEVER* remove any of the optics in the Millennia V laser. They are enclosed to minimize contamination and are designed to be cleaned in-place if required. Removing them will require a major realignment that can only be performed at the factory. Such an alignment is not covered by your warranty.

**Caution!**



It is recommended that the customer *never clean the SHG doubling crystal*. It is *very easy* to damage the crystal, and cleaning is rarely required. If you *must* clean it, first make sure the crystal is at room temperature by turning off the power supply and letting the crystal cool down. Once it is cool, blow air on it using a rubber squeeze bulb. *Do not use canned air or dry nitrogen: cold air can damage the crystal*. The crystal protrudes from the ends of the oven housing and it is very fragile. It is also *very susceptible* to damage caused by solvents. *Damage caused by cleaning is not covered by your warranty.*

1. Remove the dust cover(s) for the optic to be inspected and/or cleaned.
2. Use a squeeze bulb or dry nitrogen to blow away any dust or grit on the surface, then test to see if a normal power level returns. If power is acceptable, do not clean any further.

If canned air is used, hold the can in an upright position to avoid liquid freon from contaminating the optic.

3. If solvent cleaning is required, use a tissue folded in a hemostat to clean the optic.

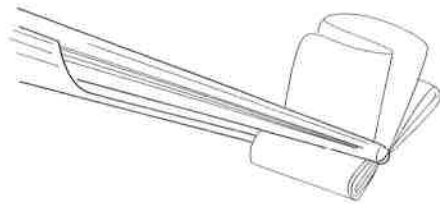

**Figure 7-1: Lens Tissue Folded for Cleaning**

- a. Fold a piece of lens tissue into a pad about 1 cm on a side and clamp it in a hemostat (Figure 7-1).
- b. If required, cut the paper with a solvent-cleaned tool to allow access to the optic.
- c. Saturate the pad with methanol, shake off the excess, resaturate, and shake again. *No not use excessive solvent!*

Excess solvent can wick or run down the surface and can attack any adhesive that might be holding the optic to the mount or base and either loosen it or, worse, contaminate the optical surface with adhesive material.

- d. Wipe the surface in a single motion.

Be careful that the hemostat does not touch the optic surface or the coating may be scratched.

4. Inspect the cleaned optic under ample light to verify the optic actually got cleaner, i.e., you did not replace one contaminant with another.
5. Replace the dust cover(s). Never leave the covers off longer than it takes to clean the optic.

This concludes the procedure for cleaning optics.

### **General Procedure for Cleaning Fiber-optic Bundles**

Prior to cleaning the fibers, it is advisable to briefly inspect the fiber end coatings for damage or burn areas.



---

Before you do this, however, turn off the power supply to ensure the diode is disarmed.

---

The fibers may be easily cleaned using a fiber holder such as Spectra-Physics P/N 0129-2872 and a small inspection microscope (50 to 100 power). In lieu of the holder, it is advisable that the fiber connector be gently held in a small clamp or vise that is lined with clean lens tissue. Whenever the exposed fiber ends are handled, *always wear* clean, dust-free finger cots or gloves.

Inspection of the fiber end coatings should reveal a uniform, bluish, smooth and shiny surface with few scratches, inclusions or dust particles.

After initial inspection, the fiber ends should be cleaned by one (or both) of two methods described below, as required, to achieve the desired results.

1. Begin the cleaning using the “drop and drag” method.
  - a. Hold the fiber so that the coated surface is facing upward, and place a sheet of lens tissue over it.
  - b. Squeeze a drop or two of methanol onto it, and slowly and steadily draw the tissue across the surface to remove dissolved contaminants and to dry the surface. Repeat as necessary, using a clean tissue each time.
2. For stubborn contaminants, use a tissue in a hemostat to clean the fiber end.
  - a. Fold a piece of tissue in half repeatedly until you have a pad about 3 to 4 mm wide (trim with clean forceps if necessary), and clamp it in a plastic hemostat (Figure 7-1).

- b. Saturate the tissue with methanol, shake off the excess, resaturate, and shake again.
- c. Gently wipe the surface in a single motion.

Take care as you wipe the surface as this method applies more stress to the coatings and can, if done too roughly or too often, *damage the fiber ends*.

Also be careful that the hemostat does not touch the optical surface or the coating may be scratched.

- d. Inspect the cleaned surface to verify the optic actually got cleaner, i.e., that you did not replace one contaminant with another.
- e. Replace the fiber bundle into the Z-head.

It is not advisable to cap or leave exposed any fiber ends that have been cleaned. This only invites further contamination and further cleaning. Cleaning must be held to a minimum to prevent stress to the coatings and the fiber itself.

This concludes the procedure for cleaning the fiber-optic bundles.



The Spectra-Physics Millennia V laser is a *Class IV—High Power Laser* whose beam is, by definition, a safety and fire hazard. Take precautions to prevent accidental exposure to both direct and reflected beams. Diffuse as well as specular beam reflections can cause severe eye or skin damage. Always wear proper eye protection when working on the laser and follow the safety precautions in Chapter 2, “Laser Safety.”

This troubleshooting guide is for use by you, the user. It is provided to assist you in isolating some of the problems that might arise while using the system. A complete repair procedure is beyond the scope of this manual. For information concerning the repair of your unit by Spectra-Physics, please call your local service representative. A list of world-wide service sites is included at the end of Chapter 9. Before you call, note your current software revision number; it can be found on the Info Menu by scrolling to the bottom of the list of specifications that are displayed on the screen.

## Troubleshooting Guide

### Symptom: The controller screen does not light up.

| Possible Causes                       | Corrective Action   |
|---------------------------------------|---|
| Power is not available to the system. | If the power supply fan is off: <ol style="list-style-type: none"> <li>a. verify that the power cord is plugged in.</li> <li>b. verify the voltage selector is set to the correct line voltage.</li> <li>c. verify the internal voltages are correct (call your Spectra-Physics service representative).</li> <li>d. verify the fuses in the power supply are not blown.</li> </ol> |
| Power supply has failed.              | Call your Spectra-Physics service representative.   |

**Symptom: Low power.**

| Possible Causes   | Corrective Action   |
|---|---|
| Dirty optics  | Clean, but do not remove the intracavity mirrors. <b>Do not attempt to clean the SHG crystal.</b>   |
| The beam is clipped.  | Call your Spectra-Physics service representative.   |
| The chiller is not turned on or there is poor or no water flow. | Verify the chiller is turned on. Make sure all the water fittings are connected. Check the chiller for the correct water level. Check the chiller's filter screen at the pump and clean it if necessary. Refer to the chiller manual. |
| The SHG temperature is not adjusted correctly.                  | Set the Millennia V to current mode, 100% current. Adjust the SHG temperature for maximum output power. For long term stability, back the SHG count down by about 5 to 10 counts. Adjust the HR for maximum output power.             |
| The Millennia V is mis-aligned.                                 | Set the Millennia V to current mode, 100% current. Adjust the HR for maximum output power.  |

**Symptom: High optical noise.**

| Possible Causes                                | Corrective Action   |
|--|---|
| The SHG temperature is not adjusted correctly. | Set the Millennia V to current mode, 100% current. Adjust the SHG temperature for maximum output power. For long term stability, back the SHG count down by about 5 to 10 counts. Adjust the HR for maximum output power. |
| The chiller is low on water.                   | Add water to the chiller. Refer to the chiller manual.  |
| The Millennia V is mis-aligned.                | Set the Millennia V to current mode, 100% current. Adjust the HR for maximum output power.  |

**Symptom: Bad mode.**

| Possible Causes                                     | Corrective Action   |
|---|---|
| The SHG temperature is not adjusted correctly       | Set the Millennia V to current mode, 100% current. Adjust the SHG temperature for maximum output power. For long term stability, back the SHG count down by about 5 to 10 counts. Adjust the HR for maximum output power. Note: This is very common at low power level due to the lack of self-heating from the 1064 nm beam. Readjust the SHG temperature as needed. |
| The beam is clipping the output telescope assembly. | Call your Spectra-Physics service representative.   |
| The Millennia V is mis-aligned.                     | Set the Millennia V to current mode, 100% current. Adjust the HR for maximum output power.  |

**Symptom: The Millennia V shuts itself off in power mode.**

| Possible Causes                                 | Corrective Action   |
|---|---|
| The Millennia V is mis-aligned.                 | Set the Millennia V to current mode, 100% current. Adjust the HR for maximum output power.  |
| The SHG temperature is not adjusted correctly.  | Set the Millennia V to current mode, 100% current. Adjust the SHG temperature for maximum output power. For long term stability, back the SHG count down by about 5 to 10 counts. Adjust the HR for maximum output power. |
| Dirty optics                                    | Clean, but do not remove the intracavity mirrors. <b>Do not attempt to clean the SHG crystal.</b>   |
| Incorrect pick-off calibration (power readout). | Call your Spectra-Physics service representative.   |

**Symptom: The Millennium V shuts itself off in current mode.**

| Possible Causes   | Corrective Action                                 |
|---|---|
| There should be no reason for the unit to shut down in current mode other than for power failure or an interlock interruption. This will show up on the controller as an error message. | Call your Spectra-Physics service representative. |

**Symptom: The Millennium V will not lase.**

| Possible Causes   | Corrective Action   |
|---|---|
| The shutter is not open.  | Move the shutter lever to the open position (O).  |
| A beam tube has fallen into the beam path                                 | Carefully remove the head cover and reinstall the beam tube.  |
| The Millennium V and power supply have not completed the turn-on sequence | The Millennium V turn-on will take approx. 20 min. to complete. Allow enough time for the turn-on sequence.   |
| An interlock is open.   | Ensure that the head cover is properly installed and latched. Ensure that the LASER ENABLE key on the power supply is in the ON position. Note: an open interlock should show up on the controller as an error. |

**Symptom: Long-term stability/beam pointing is poor.**

| Possible Causes   | Corrective Action   |
|---|---|
| The laser head is not properly locked down to the optical table | Be sure to use the clamps that were supplied with your Millennium V. These clamps were specially designed to eliminate any side loads to the Millennium V feet which causes undo stress to the resonator. |
| The jam nuts on the feet are not locked.                        | Once the laser position and height have been adjusted, the jam nuts should be adjusted all the up and tightened against the bottom plate.   |
| The routing mirrors are not installed correctly.                | If the routing mirrors are used as part of the beam delivery set-up, ensure that they are assembled and locked down correctly.  |

## Replacement Parts

The following is a list of parts that may be purchased to replace broken or misplaced components. Also listed are optional components that may be purchased to enhance your system.

| Description  | Part Number   |
|--|---------------|
| Main pc board assembly* (through S/N 1320            | 0450-1040S    |
| Main pc board assembly* (S/N 1321 through 1432)      | 04551-5180    |
| Main pc board assembly* (starting at S/N 1433)       | 0451-6850     |
| Software upgrade kit (up through S/N 1320 only)      | 0451-5020     |
| Optic retainer (10 ea.)                              | 0450-3050     |
| Doubler oven assembly, with crystal                  | 0451-0420S    |
| Light pick-off assembly                              | 0451-2480     |
| Table clamp kit                                      | 0451-2490     |
| Beam tube kit  | 0451-2500     |
| Beam tube snap adapter kit (10 ea.)                  | 0451-2510     |
| High reflector adjust drivers                        | 0451-2520     |
| Diode module assembly, new                           | 0129-4106S    |
| Diode module assembly, ETN                           | 0129-4106-ETN |
| Light bulb, white, 28 V (emission indicator, 10 ea.) | 3901-1300S    |
| Controller, Millennia V (through S/N 1432)           | TREM-C2-08-20 |
| Controller, Millennia V (starting at S/N 1433)       | TREM-C2-08-30 |
| Polarization rotator                                 | 0425-6951     |
| Beam splitter  | G0062-000     |

\* PCB assemblies are not retrofitable.



### Customer Service

At Spectra-Physics we take great pride in the reliability of our products. Considerable emphasis has been placed on controlled manufacturing methods and quality control throughout the manufacturing process. Nevertheless, even the finest precision instruments will need occasional service. We feel our instruments have excellent service records compared to competitive products, and we hope to demonstrate, in the long run, that we provide excellent service to our customers in two ways: first by providing the best equipment for the money, and second, by offering service facilities that get your instrument repaired and back to you as soon as possible.

Spectra-Physics maintains major service centers in the United States, Europe, and Japan. Additionally, there are field service offices in major United States cities. When calling for service inside the United States, dial our toll free number: **1 (800) 456-2552**. To phone for service in other countries, refer to the "Service Centers" listing located at the end of this section.

Order replacement parts directly from Spectra-Physics. For ordering or shipping instructions, or for assistance of any kind, contact your nearest sales office or service center. You will need your instrument model and serial numbers available when you call. Service data or shipping instructions will be promptly supplied.

To order optional items or other system components, or for general sales assistance, dial **1 (800) SPL-LASER** in the United States, or **1 (650) 961-2550** from anywhere else.

### Warranty

This warranty supplements the warranty contained in the specific sales order. In the event of a conflict between documents, the terms and conditions of the sales order shall prevail.

Unless otherwise specified, all parts and assemblies manufactured by Spectra-Physics are unconditionally warranted to be free of defects in workmanship and materials for a period of one year following delivery of the equipment to the F.O.B. point.

Liability under this warranty is limited to repairing, replacing, or giving credit for the purchase price of any equipment that proves defective during the warranty period, provided prior authorization for such return has been given by an authorized representative of Spectra-Physics. Spectra-Physics

will provide at its expense all parts and labor and one-way return shipping of the defective part or instrument (if required). In-warranty repaired or replaced equipment is warranted only for the remaining portion of the original warranty period applicable to the repaired or replaced equipment.

This warranty does not apply to any instrument or component not manufactured by Spectra-Physics. When products manufactured by others are included in Spectra-Physics equipment, the original manufacturer's warranty is extended to Spectra-Physics customers. When products manufactured by others are used in conjunction with Spectra-Physics equipment, this warranty is extended only to the equipment manufactured by Spectra-Physics.

This warranty also does not apply to equipment or components that, upon inspection by Spectra-Physics, discloses to be defective or unworkable due to abuse, mishandling, misuse, alteration, negligence, improper installation, unauthorized modification, damage in transit, or other causes beyond the control of Spectra-Physics.

This warranty is in lieu of all other warranties, expressed or implied, and does not cover incidental or consequential loss.

The above warranty is valid for units purchased and used in the United States only. Products shipped outside the United States are subject to a warranty surcharge.

### ***Return of the Instrument for Repair***

Contact your nearest Spectra-Physics field sales office, service center, or local distributor for shipping instructions or an on-site service appointment. You are responsible for one-way shipment of the defective part or instrument to Spectra-Physics.

We encourage you to use the original packing boxes to secure instruments during shipment. If shipping boxes have been lost or destroyed, we recommend that you order new ones. We can return instruments only in Spectra-Physics containers.

**Warning!**



---

Always drain the cooling water from the laser head before shipping. Water expands as it freezes and will damage the laser. Even during warm spells or summer months, freezing may occur at high altitudes or in the cargo hold of aircraft. Such damage is excluded from warranty coverage.

---

**Service Centers****Benelux**

Spectra-Physics BV  
Prof. Dr. Dorgelolaan 20  
5613 AM Eindhoven  
The Netherlands  
Telephone: (31) 40 265 99 59  
Fax: (31) 40 243 99 22

**France**

Spectra-Physics S.A.R.L.  
Z.A. de Courtaboeuf  
Avenue de Scandinavie  
91941 Les Ullis Cedex  
Telephone: (33) 1-69 18 63 10  
Fax: (33) 1-6907 60 93

**Germany and Export Countries\***

Spectra-Physics GmbH  
Siemensstrasse 20  
D-64289 Darmstadt-Kranichstein  
Telephone: (49) 06151 7080  
Fax: (49) 6151 79102

**Japan (East)**

Spectra-Physics KK  
East Regional Office  
Daiwa-Nakameguro Building  
4-6-1 Nakameguro  
Meguro-ku, Tokyo 153  
Telephone: (81) 3-3794-5511  
Fax: (81) 3-3794-5510

**Japan (West)**

Spectra-Physics KK  
West Regional Office  
Cycnas Building  
2-19 Uchihirano-Cho  
Chuo-ku, Osaka  
Telephone: (81) 3-6941-7331  
Fax: (81) 6941-2700

*\* All European and Middle Eastern countries in this region not included elsewhere on this list.*

**Service Centers (cont.)**

**United Kingdom**

Spectra-Physics Ltd.  
Boundary Way  
Hemel Hempstead  
Herts, HP2 7SH  
Telephone: (44) 1442-258100  
Fax: (44) 1442-68538

**United States and Export Countries\***

Spectra-Physics  
1330 Terra Bella Avenue  
Mountain View, CA 94043  
Telephone: (800) 456-2552 (Service) or  
(800) SPL-LASER (Sales) or  
(800) 775-5273 (Sales) or  
(650) 961-2550 (Operator)  
Fax: (650) 964-3584  
e-mail: service@splasers.com  
sales@splasers.com  
Internet: www.spectra-physics.com

*\*\*And all countries not included elsewhere on this list.*

Listed below are all the status codes and messages that might be displayed on the controller (not the T40 power supply) while using the Millennia V system. Most codes are self-explanatory and most errors can be corrected by the user. In the event the error cannot be corrected, or the action required to correct the error is not known, call your Spectra-Physics service representative. Before calling, however, write down the code and message.

Code 0 to 126 are generated by the T40 power supply, codes 127 and up are generated by the Millennia V laser head. Codes 142 to 147 are latched interlock messages that indicate the T40 shut off without a command to do so. These latched interlock messages are cleared by either:

- a. pressing the LASER POWER switch on the controller, or
- b. sending the *OFF* command through the RS232 port.

The Info menu HST line on the controller lists the three most recent status codes with the most recent listed first. The RS232 *?H* query reports the most recent 16 codes, again with the most recent listed first.

| Code | Message   |
|------|---|
| 0    | Everything is fine  |
| 1    | Power Mode Ready  |
| 2    | Current Mode Ready  |
| 3    | Power Mode Adjust   |
| 4    | Current Mode Adjust   |
| 5    | Diodes off, temperature stable, ready to turn on            |
| 8    | Power Supply in Standby mode                                |
| 61   | EEPROM data read error                                      |
| 62   | AC Fault, >50ms   |
| 63   | System Boot Marker  |
| 64   | Communications error  |
| 65   | Laser Power Outside Ready Range                             |
| 66   | Power adjust timeout  |
| 67   | Passbank over temp  |
| 68   | Passbanks current limited <i>see p6-11 for possible fix</i> |
| 69   | Diode Module ilock test: bad voltage                        |
| 70   | Diode Module ilock test: bad logic                          |
| 71   | Diode Module Safety Check 2: bad voltage                    |
| 72   | Diode Module Safety Check 2: bad logic                      |
| 73   | Diode Module Safety Check 1: bad voltage                    |

| Code | Message                                     |
|------|---|
| 74   | Diode Module Safety Check 1: bad logic      |
| 81   | EEPROM data not available @ startup         |
| 82   | EEPROM fault on write condition             |
| 83   | Bad config for uP                           |
| 84   | Compressor failed startup test              |
| 85   | Heater failed startup test                  |
| 86   | Shorted therm #2 in power supply            |
| 87   | Open thermistr #2 in power supply           |
| 88   | Shorted therm #1 in power supply            |
| 89   | Open thermistr #1 in power supply           |
| 90   | Multiple errors                             |
| 91   | Diode over temperature                      |
| 92   | Diode under temperature                     |
| 93   | Current limit passbank 2 active             |
| 94   | Current limit passbank 1 active             |
| 95   | Power supply interlock active               |
| 96   | Safety relay for D2 closed, s.b. open       |
| 97   | Safety relay for D2 open, s.b. closed       |
| 98   | Safety relay for D1 closed, s.b. open       |
| 99   | Safety relay for D1 open, s.b. closed       |
| 127  | Everything's fine                           |
| 130  | Z-head thermistor shorted                   |
| 131  | Z-head temperature high                     |
| 132  | Z-head thermistor open                      |
| 133  | SHG duty cycle error                        |
| 134  | SHG thermistor shorted                      |
| 135  | SHG thermistor or heater open (check cable) |
| 136  | Head cover interlock open                   |
| 140  | Controller interlock open                   |
| 141  | Communications error between head & supply  |
| 142  | System shut off: check HST on info menu     |
| 143  | System shut off: pwr sply interlock         |
| 144  | System shut off: head interlock             |
| 145  | System shut off: REMOTE interlock           |
| 146  | System shut off: power adjust timeout       |
| 147  | System shut off: current limit              |
| 148  | Controller communications time out          |
| 200  | Diode calibration required                  |
| 201  | Diode1 curr calib required                  |
| 202  | Diode2 curr calib required                  |
| 203  | Diode3 curr calib required                  |
| 204  | Diode4 curr calib required                  |
| 205  | Diode1 temp calib required                  |
| 206  | Diode2 temp calib required                  |
| 207  | Diode3 temp calib required                  |
| 208  | Diode4 temp calib required                  |

# Notes

---

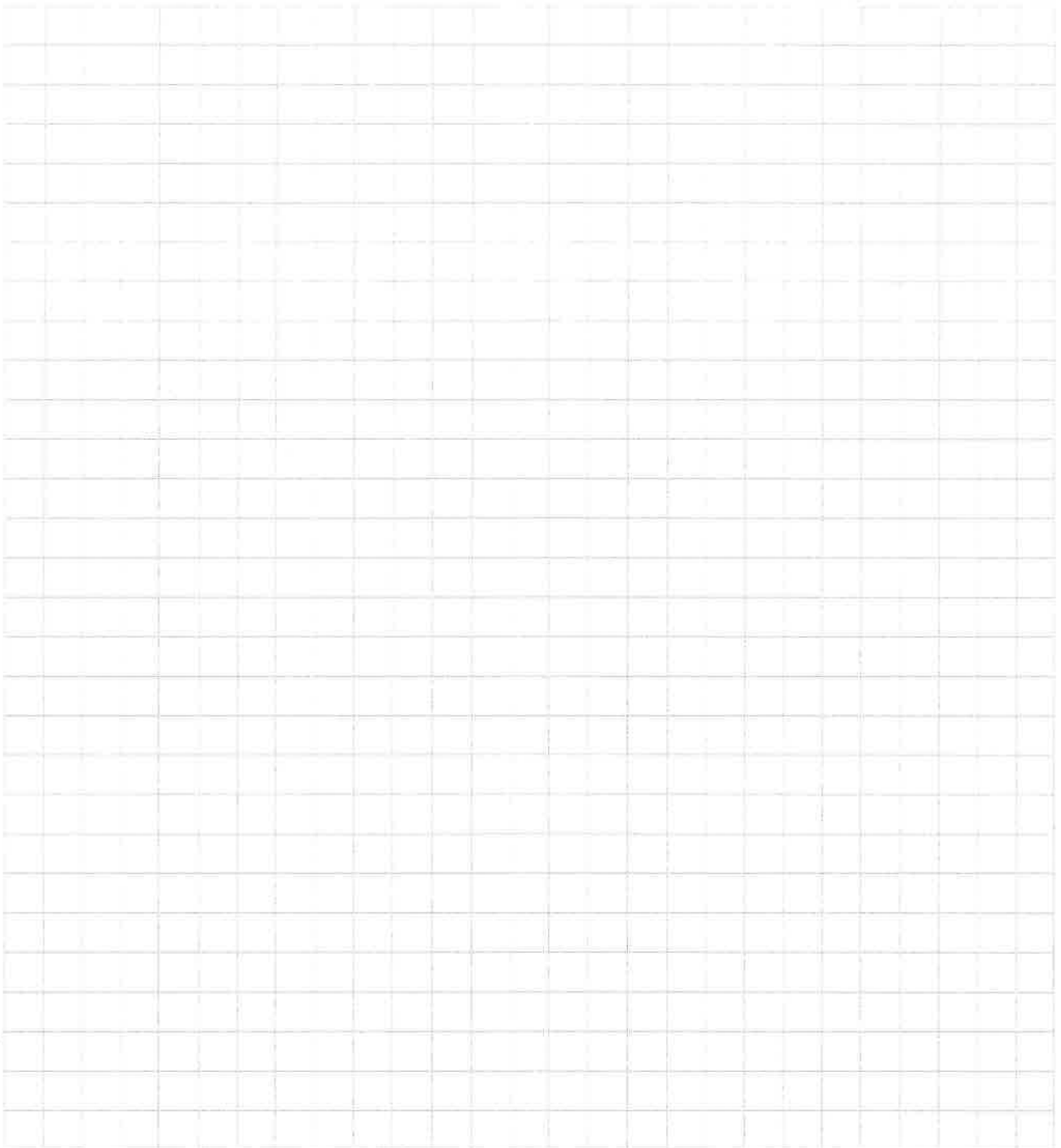

A large grid of graph paper with 20 columns and 30 rows. The grid is composed of thin, light gray lines forming a uniform pattern of squares. The grid is intended for drawing or plotting data.







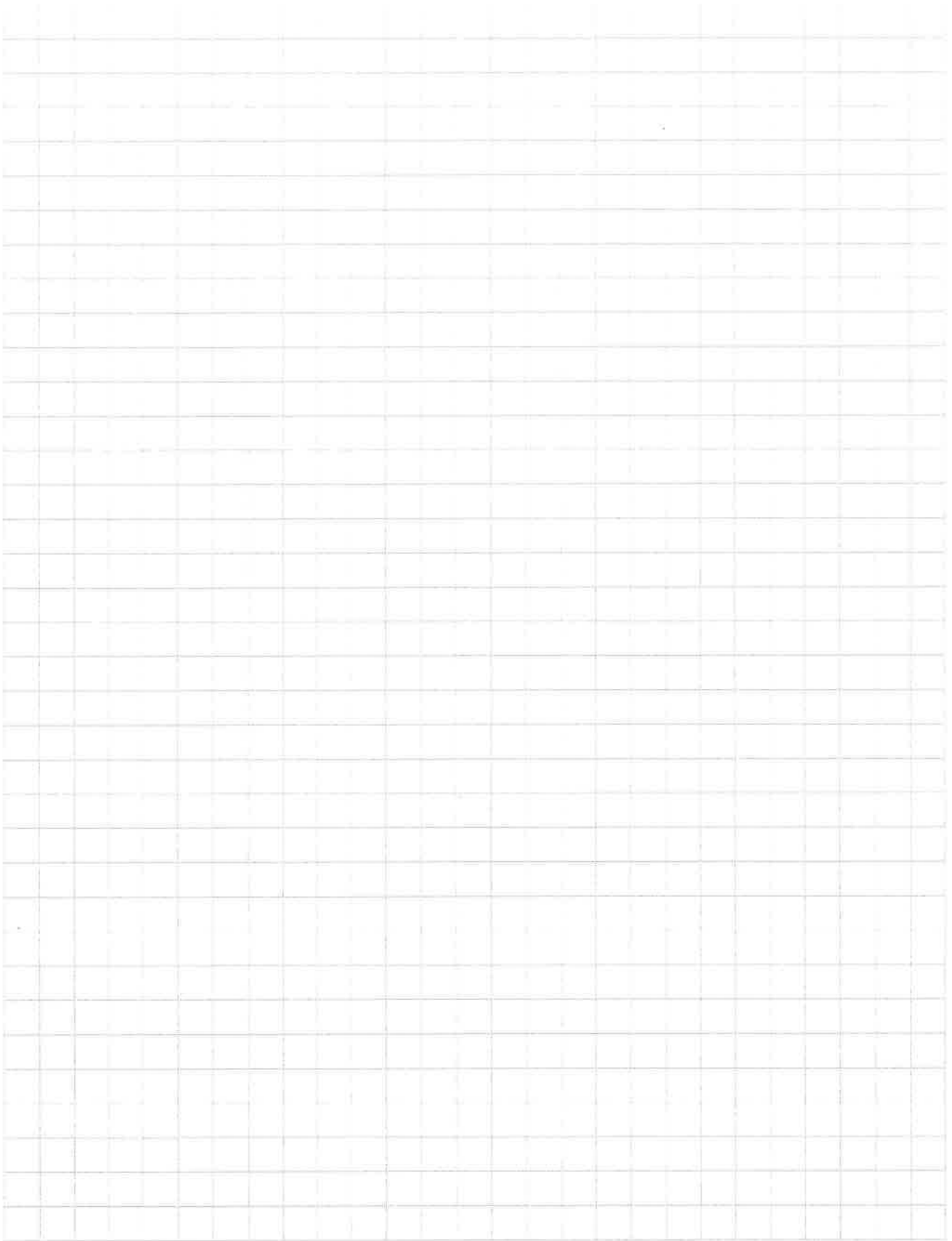



# Spectra-Physics User's Manual— Problems and Solutions

---

We have provided this form to encourage you to tell us about any difficulties you have experienced in using your Spectra-Physics instrument or its manual—problems that did not require a formal call or letter to our service department, but that you feel should be remedied. We are always interested in improving our products and manuals, and we appreciate all suggestions.

Thank you.

**From:**

Name \_\_\_\_\_

Company or Institution \_\_\_\_\_

Department \_\_\_\_\_

Address \_\_\_\_\_

Instrument Model Number \_\_\_\_\_ Serial Number \_\_\_\_\_

**Problem:** \_\_\_\_\_

\_\_\_\_\_

\_\_\_\_\_

\_\_\_\_\_

**Suggested Solution(s):** \_\_\_\_\_

\_\_\_\_\_

**Mail To:**

Spectra-Physics, Inc  
Diode-Pumped Solid State Product Manager  
1330 Terra Bella Avenue  
Post Office Box 7013  
Mountain View, CA 94039-7013  
U.S.A.

E-mail: [sales@splasers.com](mailto:sales@splasers.com)  
<http://www.splasers.com>

**FAX to:**

Attention: Diode-Pumped Solid State Product Manager  
(650) 969-3546

