

This LED driver is adapted from SparkFun femtobuck design.  
I've added a trim pot to control the driver. It should output constant 330 mA to LEDs.

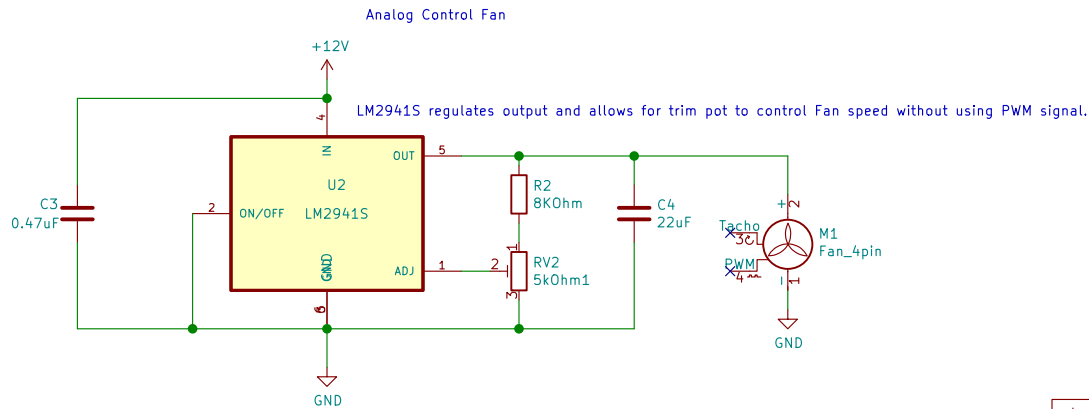
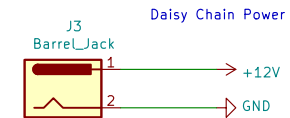
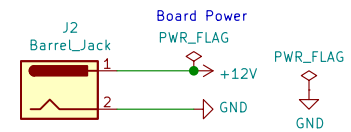

plampkin@wisc.edu Philip Lampkin Gellman Group Department of Chemistry <b>University of Wisconsin-Madison</b>	
Sheet: / File: driver.sch	
<b>Title: Analog Photoreactor Driver</b>	
Size: USLetter	Date: 2021-01-19
KiCad E.D.A. kicad 5.1.8+dfsg1-1+b1	Rev: 1.0.0 Id: 1/1